

C

CHLOROPLAST THYLAKOID SPACE

PS-II / PS-I  
CHLOROPLAST THYLAKOID MEMBRANE

CHLOROPLAST STROMA

?

● = ELECTRON TRANSPORT CHAIN COMPONENT  
☀ = HEAT ENERGY ☀ = CHEMICAL ENERGY

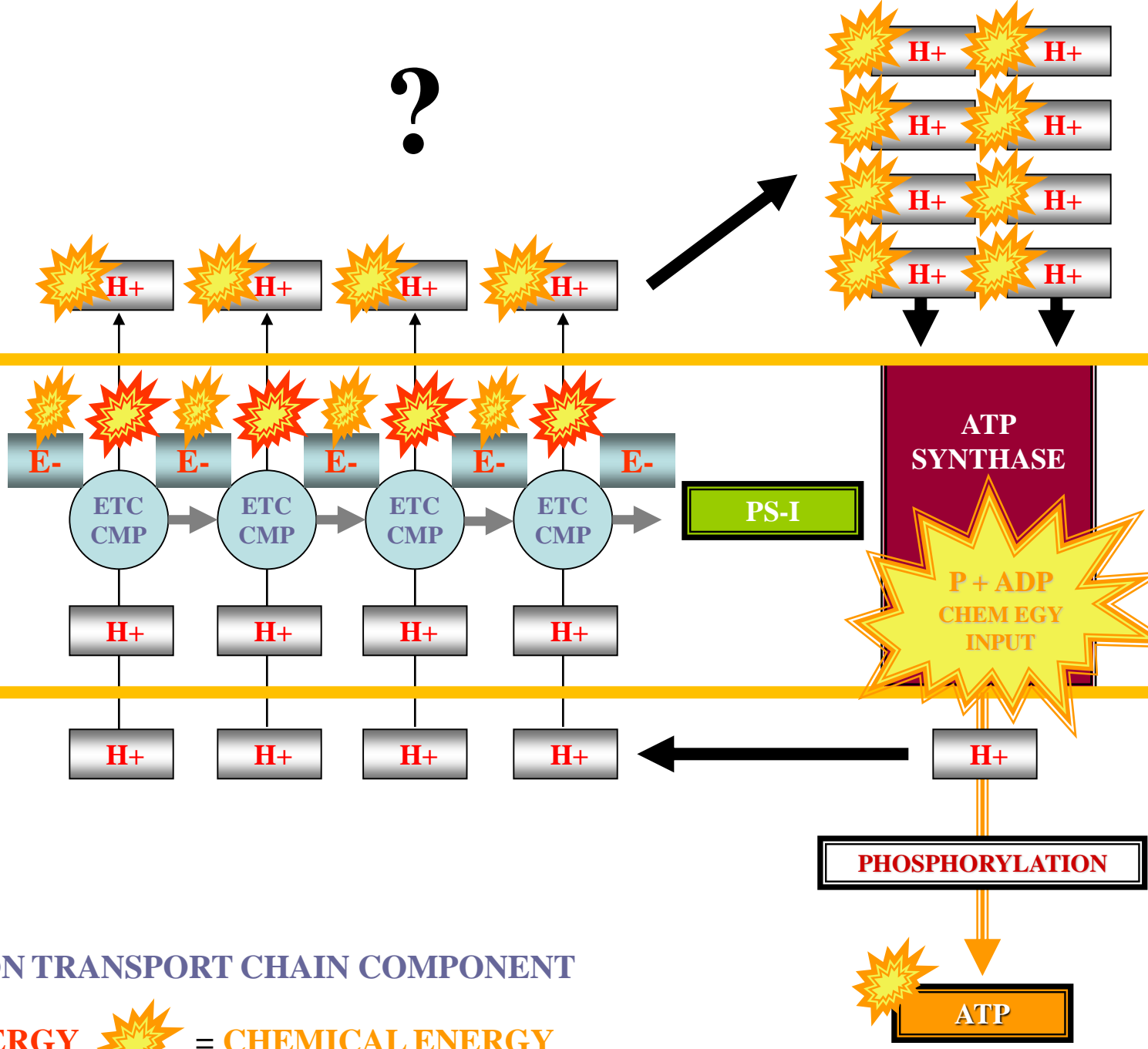



**CHLOROPLAST  
THYLAKOID  
SPACE**

# CHEMIOSMOTIC PHOSPHORYLATION MODEL

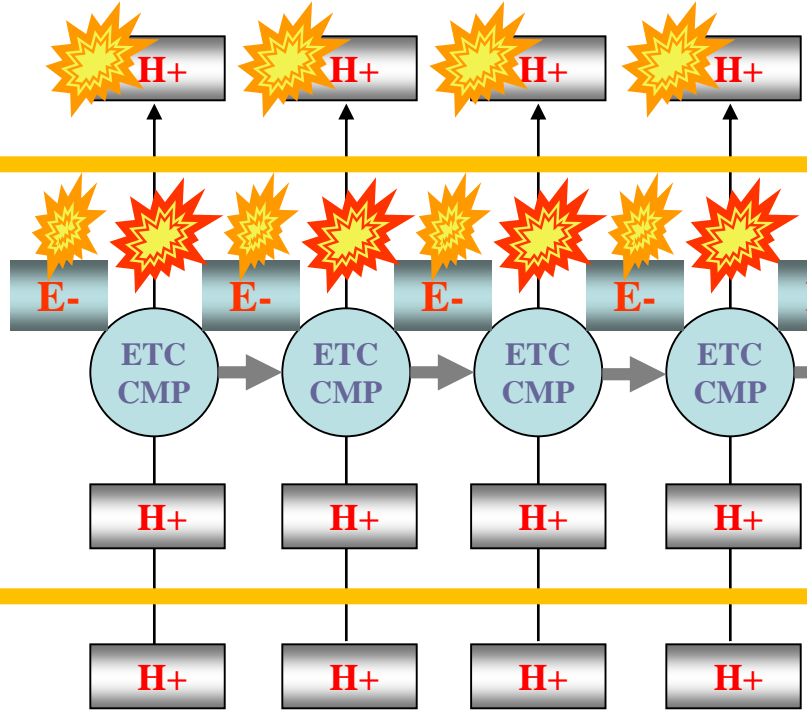
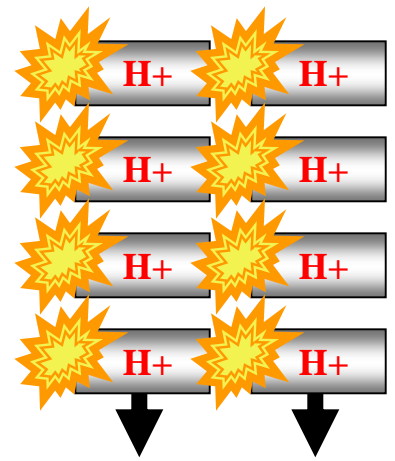

**PS-II / PS-I**

**CHLOROPLAST  
THYLAKOID  
MEMBRANE**

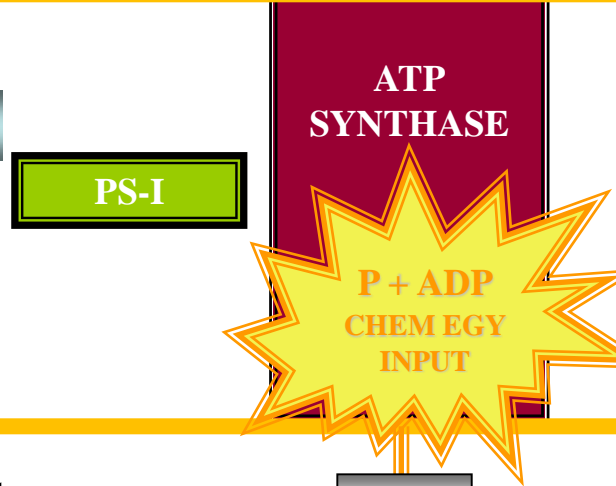

**CHLOROPLAST  
STROMA**

● = ELECTRON TRANSPORT CHAIN COMPONENT

★ = HEAT ENERGY    ★ = CHEMICAL ENERGY

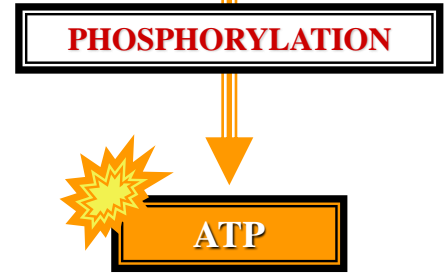

# PHOTOSYNTHESIS

## CHLOROPLAST

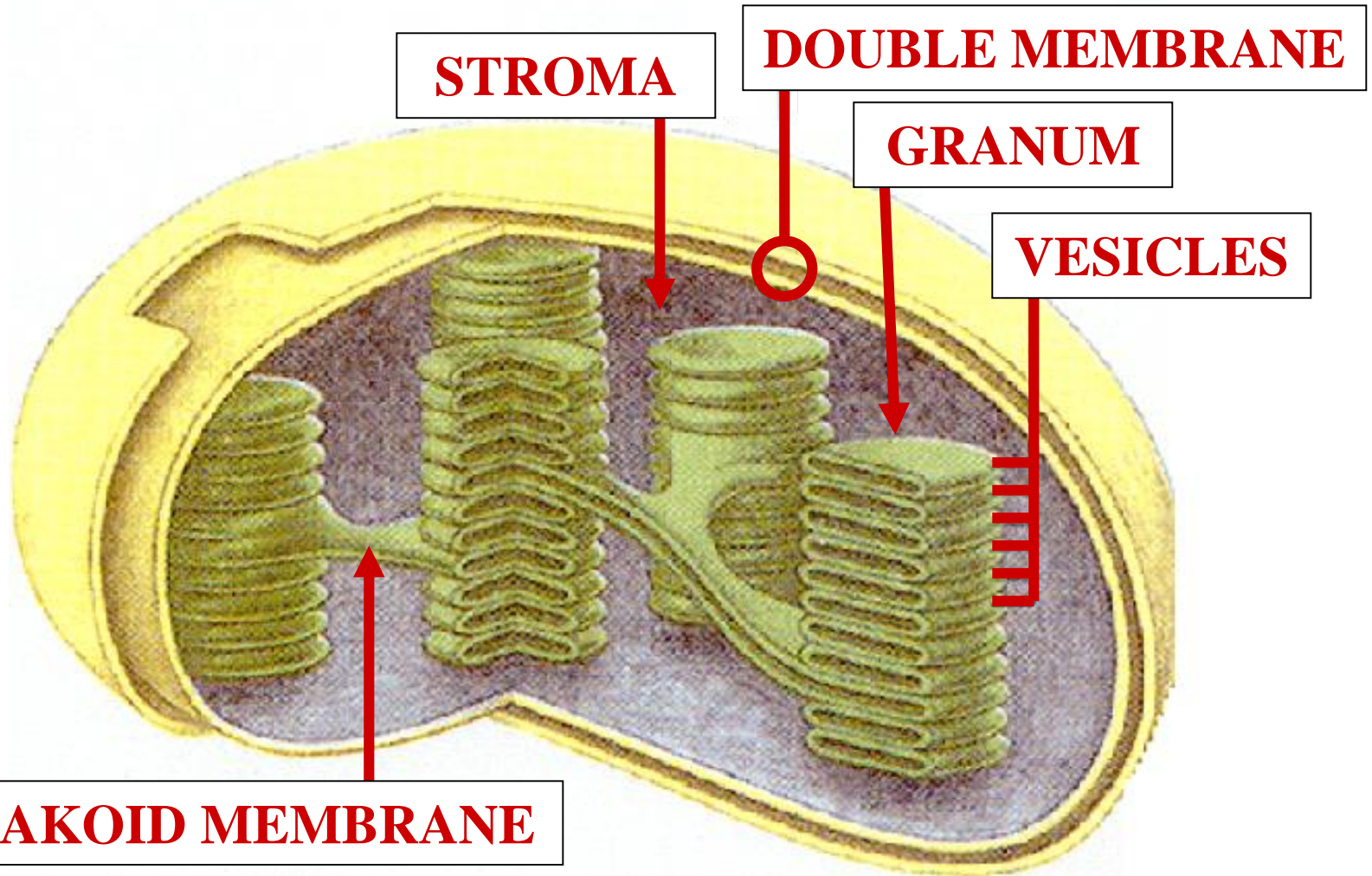

# CHEMIOSMOTIC PHOSPHORYLATION MODEL

MITOCHONDRION CRISTAE SPACE

E- DONORS  
MITOCHONDRION CRISTAE MEMBRANE

MITOCHONDRION MATRIX

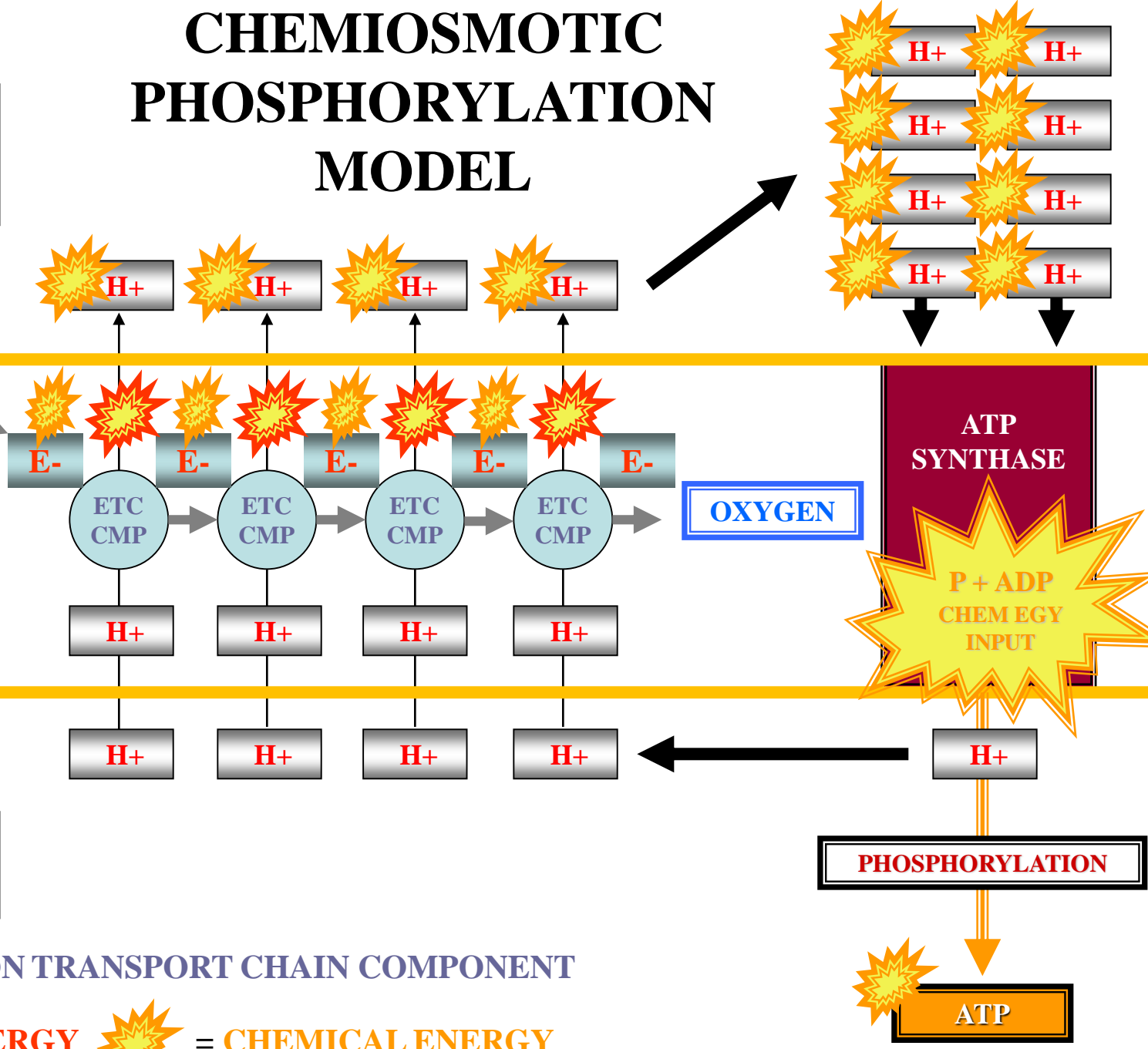



L

# CHEMIOSMOTIC PHOSPHORYLATION MITOCHONDRION



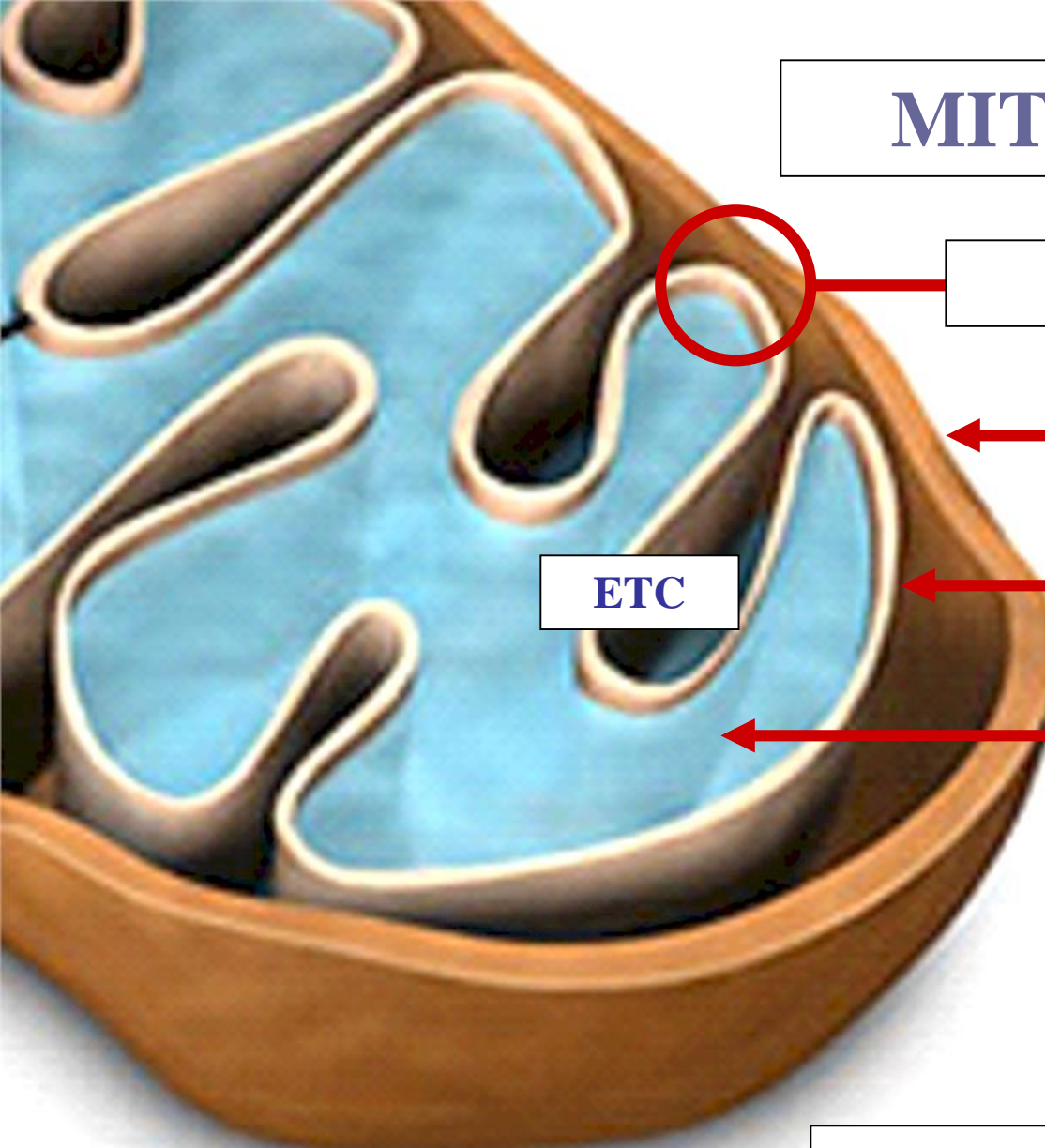

# MITOCHONDRION

**DOUBLE MEMBRANE**

**OUTER MEMBRANE**

**ETC**

**CRISTAE MEMBRANE**

**MATRIX**

# CELL CYTOSOL

 **ETC**

# ELECTRON TRANSPORT CHAIN

## MITOCHONDRION CRISTAE

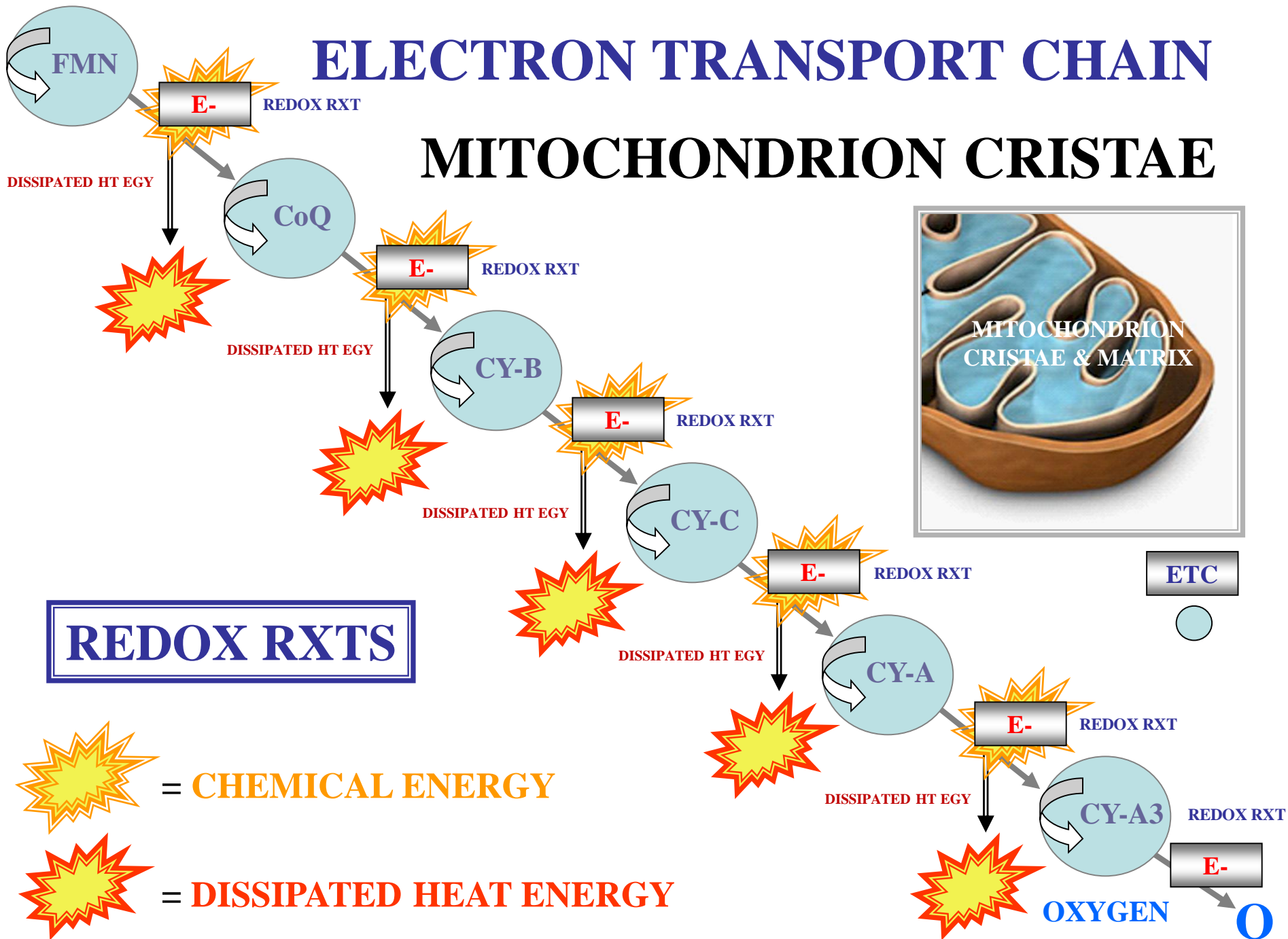

# CHEMIOSMOTIC PHOSPHORYLATION MODEL

MITOCHONDRION CRISTAE SPACE

MITOCHONDRION CRISTAE MEMBRANE

MITOCHONDRION MATRIX

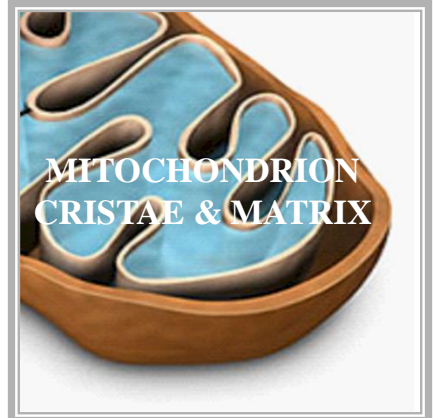
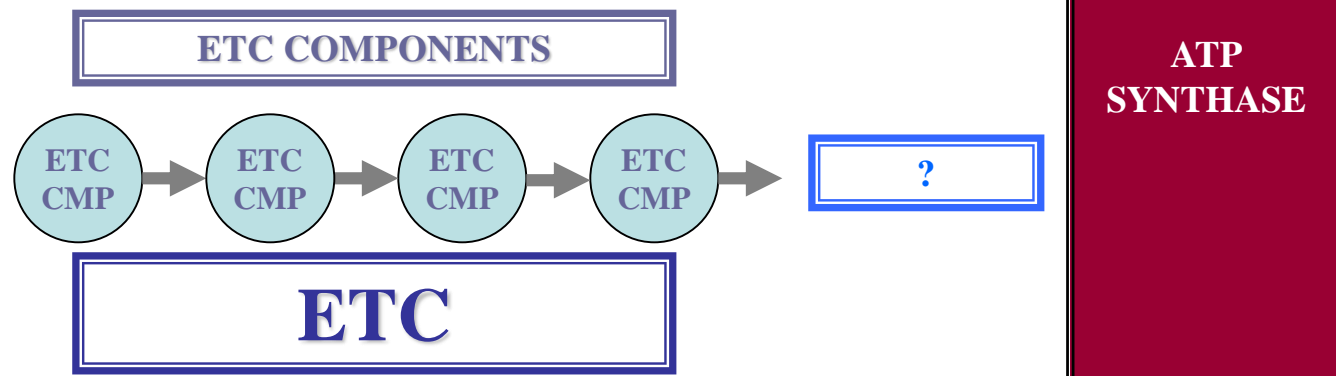

● = ELECTRON TRANSPORT CHAIN COMPONENT

☀ = HEAT ENERGY

☀ = CHEMICAL ENERGY

# CHEMIOSMOTIC PHOSPHORYLATION MODEL

MITOCHONDRION CRISTAE SPACE

E- DONORS



ETC COMPONENTS

MITOCHONDRION CRISTAE MEMBRANE

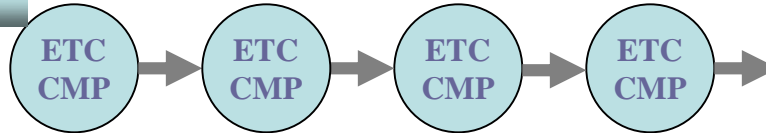

ATP SYNTHASE

ETC

H+

H+

H+

H+

MITOCHONDRION MATRIX

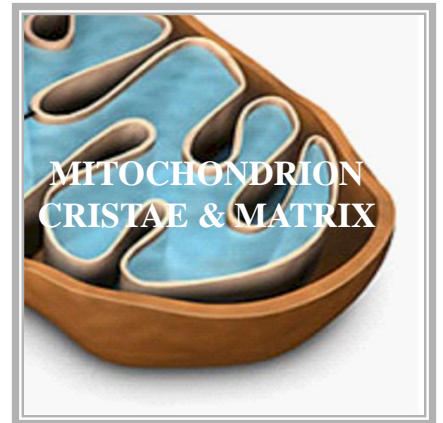

MITOCHONDRION CRISTAE & MATRIX

 = ELECTRON TRANSPORT CHAIN COMPONENT

 = HEAT ENERGY

 = CHEMICAL ENERGY

# CHEMIOSMOTIC PHOSPHORYLATION MODEL

MITOCHONDRION CRISTAE SPACE

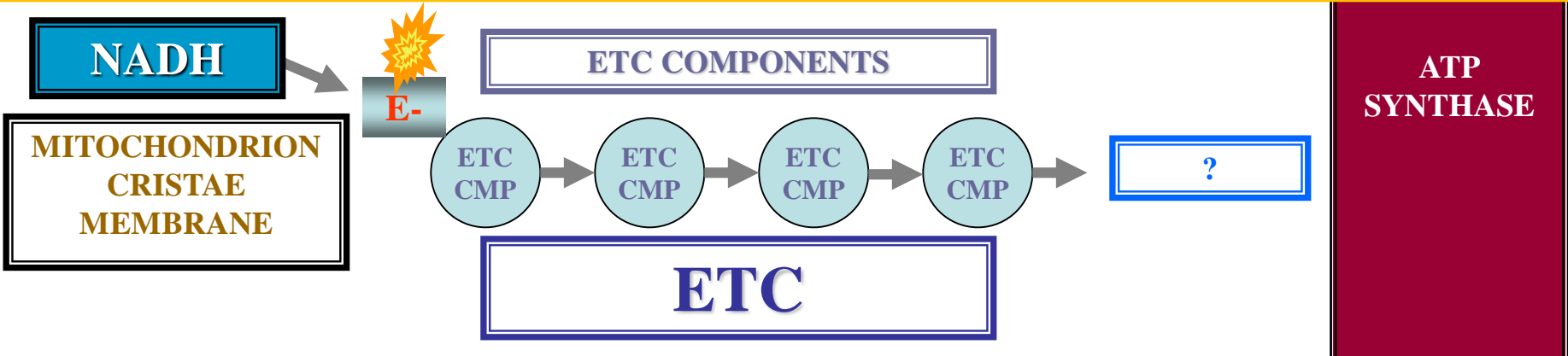

MITOCHONDRION MATRIX

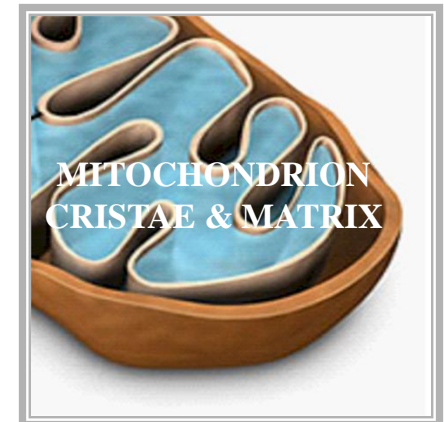

 = ELECTRON TRANSPORT CHAIN COMPONENT

 = HEAT ENERGY

 = CHEMICAL ENERGY

# CHEMIOSMOTIC PHOSPHORYLATION MODEL

MITOCHONDRION CRISTAE SPACE

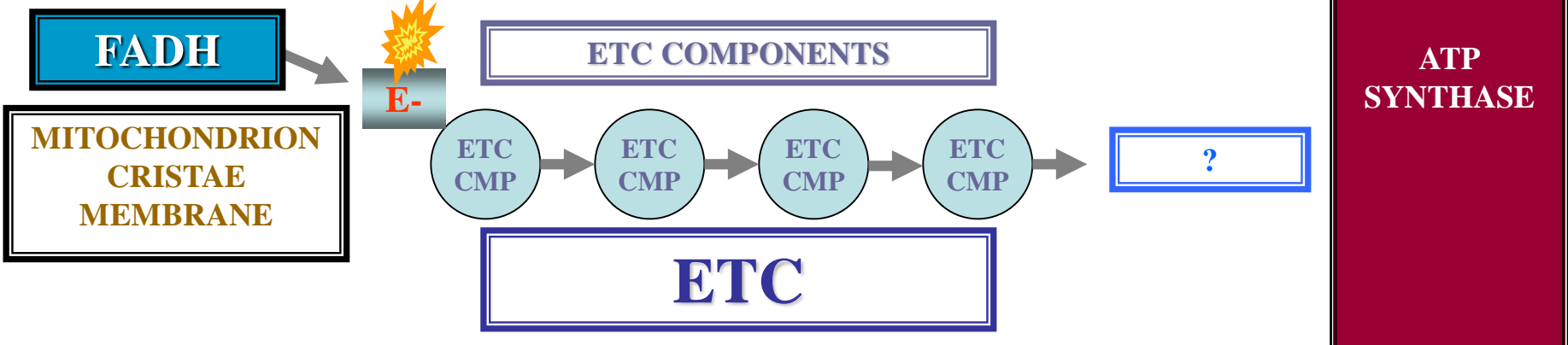

MITOCHONDRION MATRIX

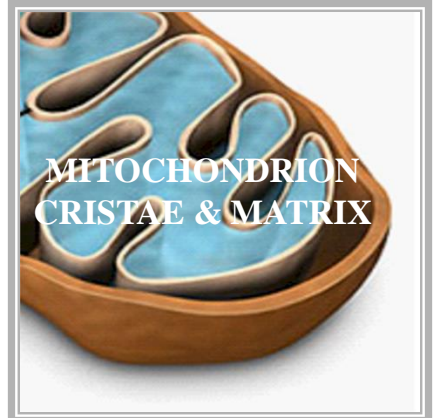

● = ELECTRON TRANSPORT CHAIN COMPONENT

★ = HEAT ENERGY

★ = CHEMICAL ENERGY

# CHEMIOSMOTIC PHOSPHORYLATION MODEL

MITOCHONDRION CRISTAE SPACE

NADH

MITOCHONDRION CRISTAE MEMBRANE



ETC COMPONENTS

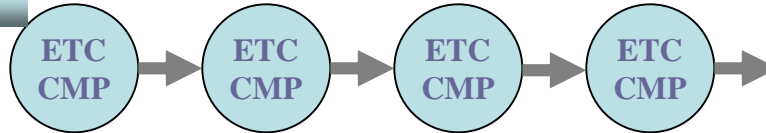

ATP SYNTHASE

ETC

H+

H+

H+

H+

MITOCHONDRION MATRIX

 = ELECTRON TRANSPORT CHAIN COMPONENT

 = HEAT ENERGY

 = CHEMICAL ENERGY

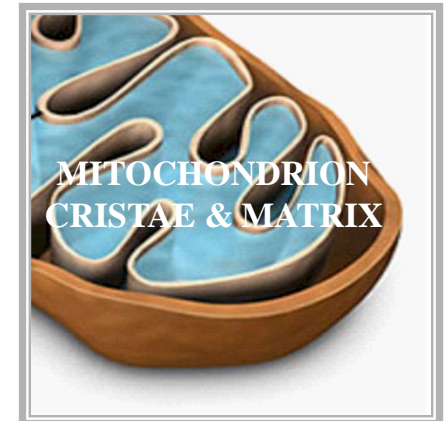



# CHEMIOSMOTIC PHOSPHORYLATION MODEL

MITOCHONDRION CRISTAE SPACE

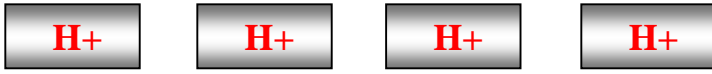
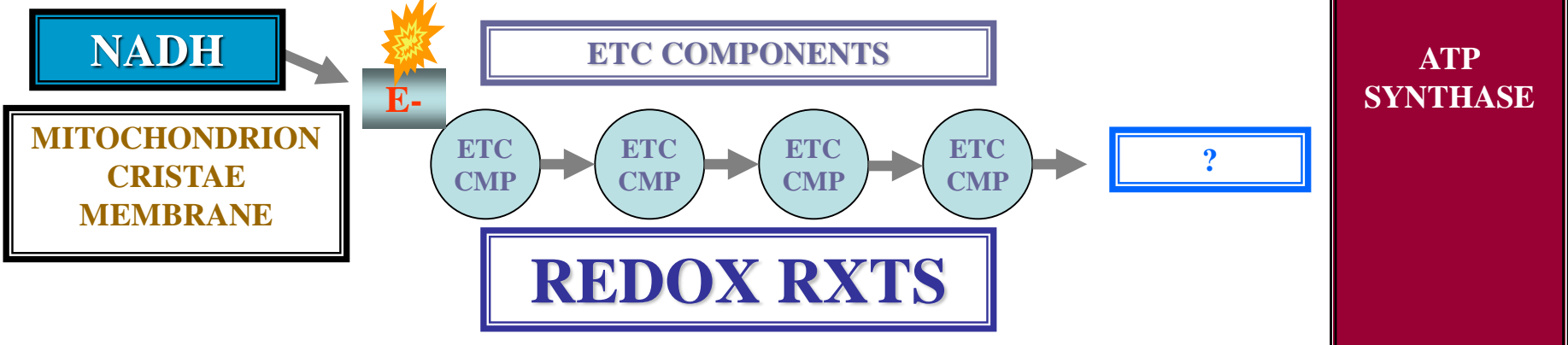

MITOCHONDRION MATRIX



 = ELECTRON TRANSPORT CHAIN COMPONENT

 = HEAT ENERGY

 = CHEMICAL ENERGY





# CHEMIOSMOTIC PHOSPHORYLATION MODEL

MITOCHONDRION CRISTAE SPACE

NADH

MITOCHONDRION CRISTAE MEMBRANE

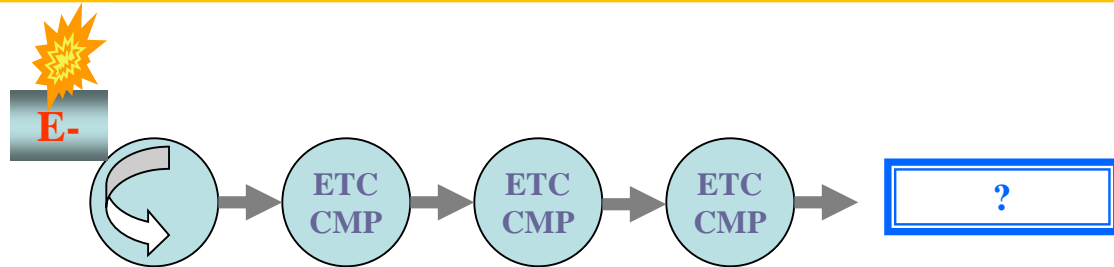

ATP SYNTHASE

H+

H+

H+

H+

MITOCHONDRION MATRIX

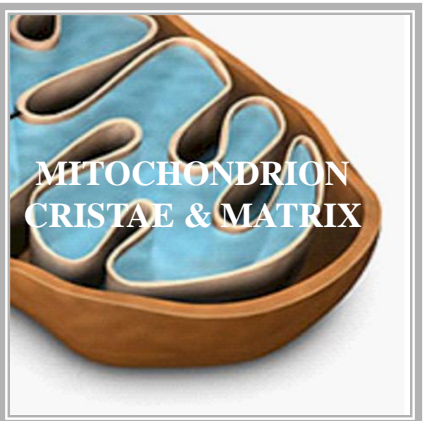

 = ELECTRON TRANSPORT CHAIN COMPONENT

 = HEAT ENERGY

 = CHEMICAL ENERGY

# CHEMIOSMOTIC PHOSPHORYLATION MODEL

MITOCHONDRION CRISTAE SPACE

NADH

MITOCHONDRION CRISTAE MEMBRANE

ATP SYNTHASE

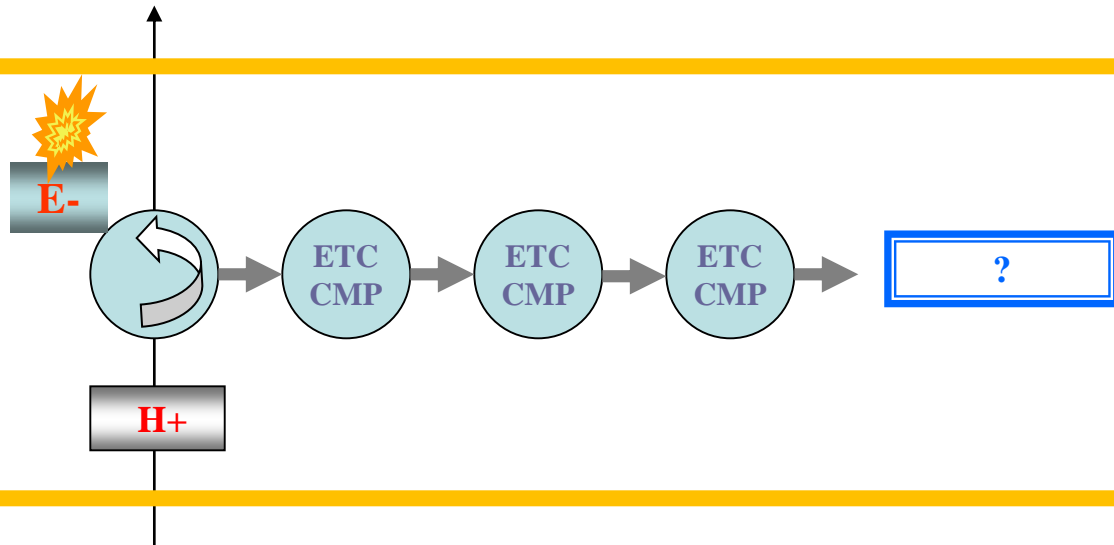

MITOCHONDRION MATRIX

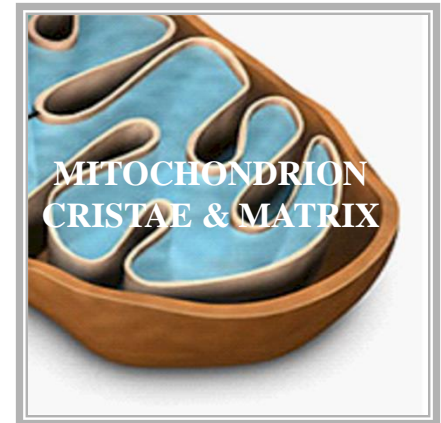

● = ELECTRON TRANSPORT CHAIN COMPONENT

★ = HEAT ENERGY

★ = CHEMICAL ENERGY

# CHEMIOSMOTIC PHOSPHORYLATION MODEL

MITOCHONDRION CRISTAE SPACE

NADH

MITOCHONDRION CRISTAE MEMBRANE

ATP SYNTHASE

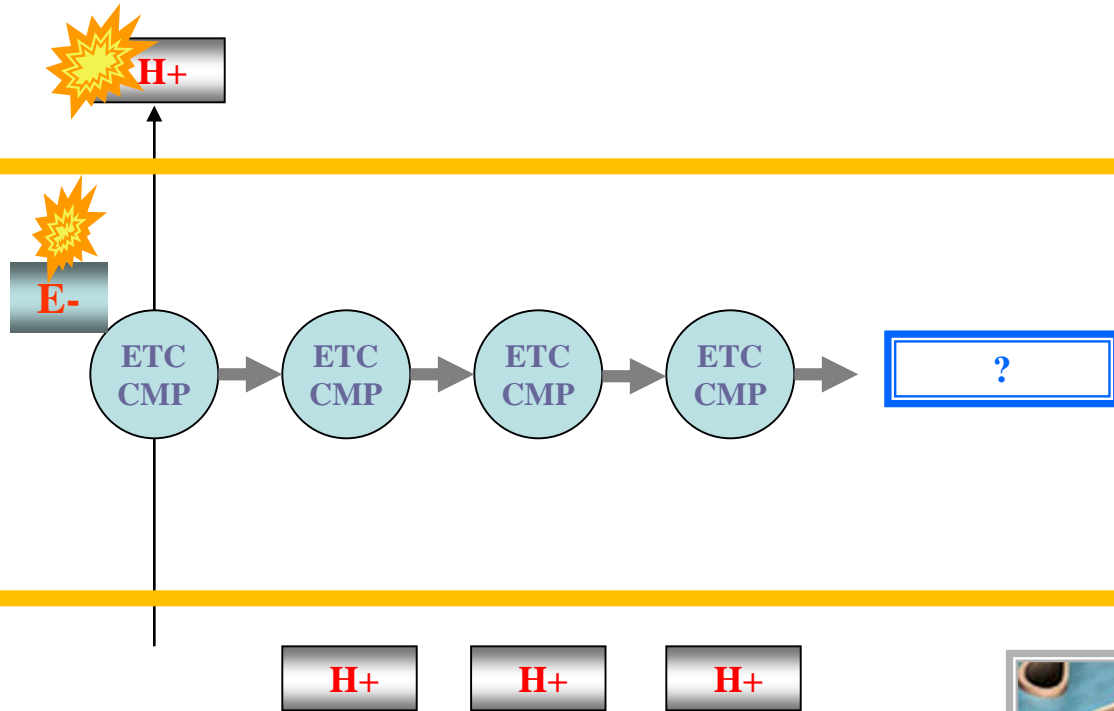

MITOCHONDRION MATRIX



● = ELECTRON TRANSPORT CHAIN COMPONENT

★ = HEAT ENERGY

★ = CHEMICAL ENERGY

# CHEMIOSMOTIC PHOSPHORYLATION MODEL

MITOCHONDRION CRISTAE SPACE



NADH

MITOCHONDRION CRISTAE MEMBRANE

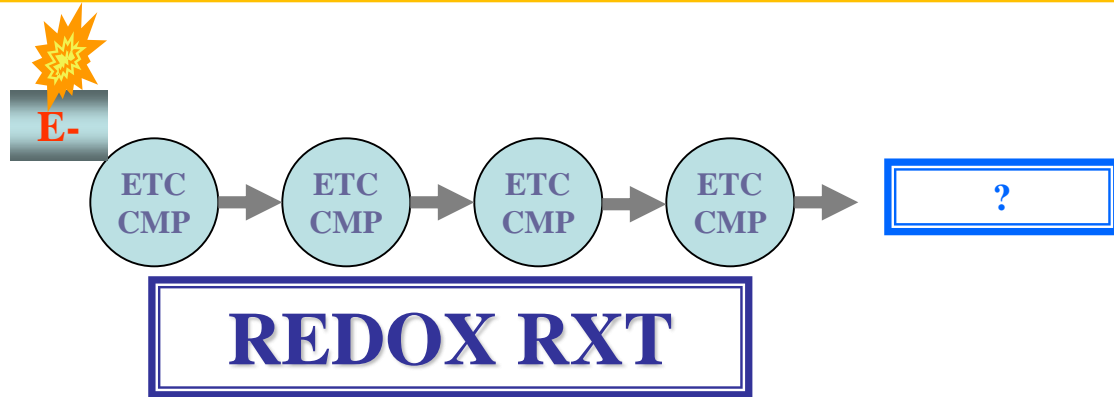

H+

H+

H+

MITOCHONDRION MATRIX



○ = ELECTRON TRANSPORT CHAIN COMPONENT

★ = HEAT ENERGY

★ = CHEMICAL ENERGY



# CHEMIOSMOTIC PHOSPHORYLATION MODEL

MITOCHONDRION CRISTAE SPACE



NADH

MITOCHONDRION CRISTAE MEMBRANE

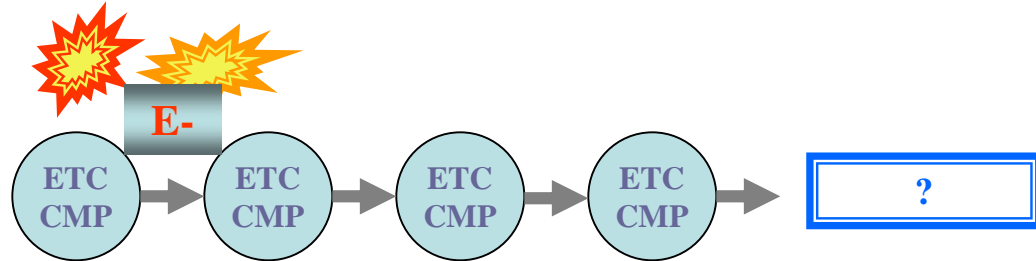

ATP SYNTHASE

H+

H+

H+

MITOCHONDRION MATRIX

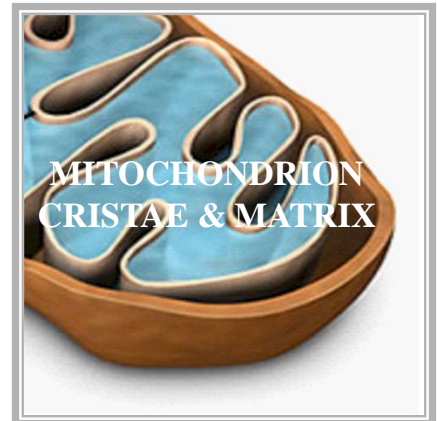

 = ELECTRON TRANSPORT CHAIN COMPONENT

 = HEAT ENERGY

 = CHEMICAL ENERGY



# CHEMIOSMOTIC PHOSPHORYLATION MODEL

MITOCHONDRION CRISTAE SPACE



NADH

MITOCHONDRION CRISTAE MEMBRANE

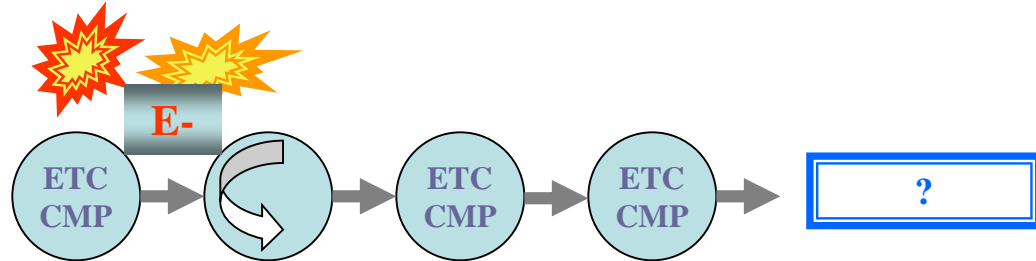

ATP SYNTHASE

H+

H+

H+

MITOCHONDRION MATRIX

 = ELECTRON TRANSPORT CHAIN COMPONENT

 = HEAT ENERGY

 = CHEMICAL ENERGY



# CHEMIOSMOTIC PHOSPHORYLATION MODEL

MITOCHONDRION CRISTAE SPACE

NADH

MITOCHONDRION CRISTAE MEMBRANE

ATP SYNTHASE

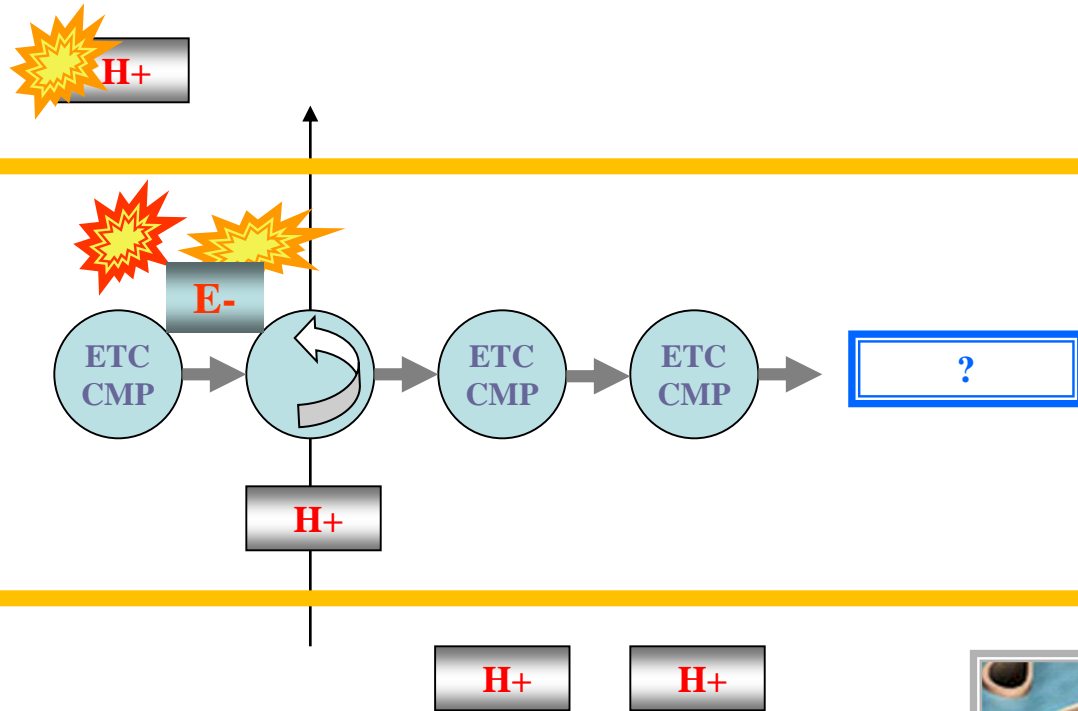

MITOCHONDRION MATRIX

● = ELECTRON TRANSPORT CHAIN COMPONENT

★ = HEAT ENERGY

★ = CHEMICAL ENERGY



# CHEMIOSMOTIC PHOSPHORYLATION MODEL

MITOCHONDRION CRISTAE SPACE



NADH

MITOCHONDRION CRISTAE MEMBRANE

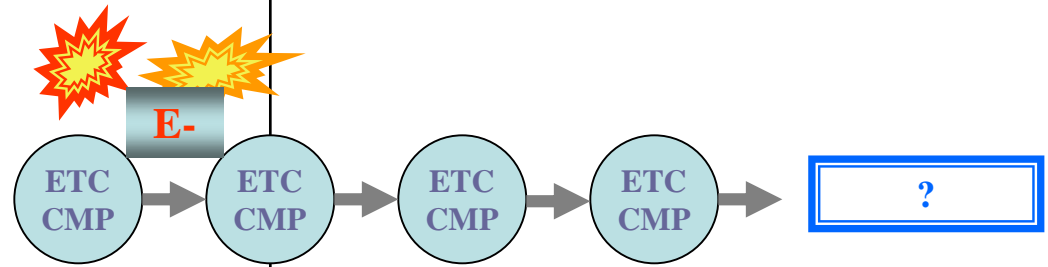

ATP SYNTHASE



MITOCHONDRION MATRIX

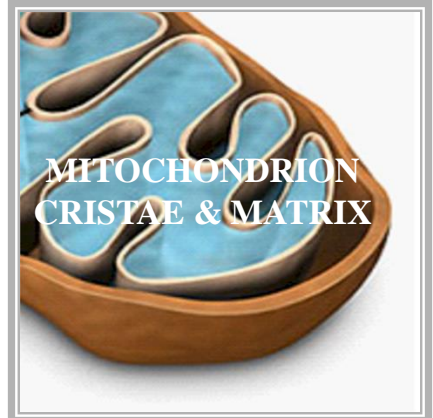

 = ELECTRON TRANSPORT CHAIN COMPONENT

 = HEAT ENERGY

 = CHEMICAL ENERGY



# CHEMIOSMOTIC PHOSPHORYLATION MODEL

MITOCHONDRION CRISTAE SPACE

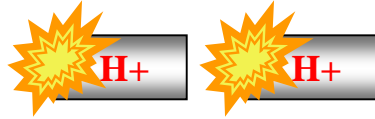

NADH

MITOCHONDRION CRISTAE MEMBRANE

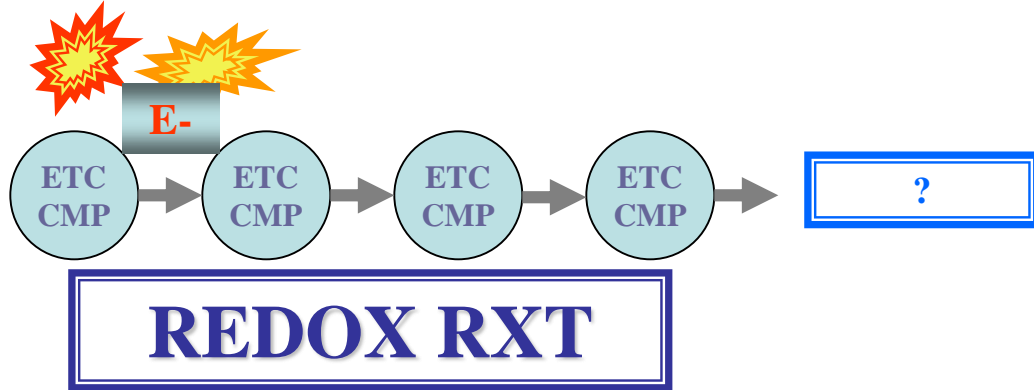

ATP SYNTHASE

H+

H+

MITOCHONDRION MATRIX



MITOCHONDRION CRISTAE & MATRIX

 = ELECTRON TRANSPORT CHAIN COMPONENT

 = HEAT ENERGY

 = CHEMICAL ENERGY



# CHEMIOSMOTIC PHOSPHORYLATION MODEL

MITOCHONDRION CRISTAE SPACE

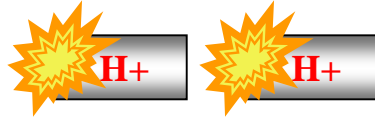

NADH

MITOCHONDRION CRISTAE MEMBRANE

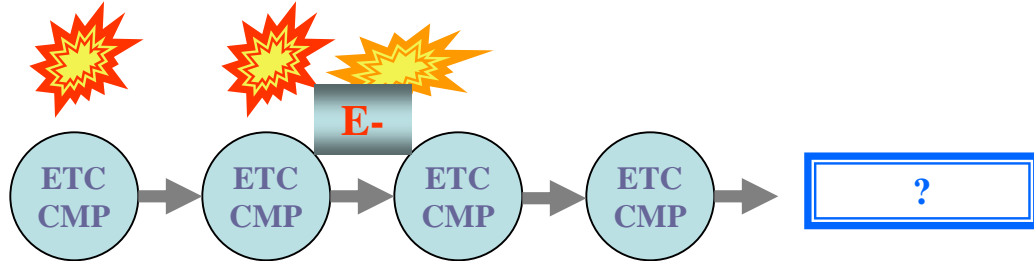

ATP SYNTHASE

H+

H+

MITOCHONDRION MATRIX

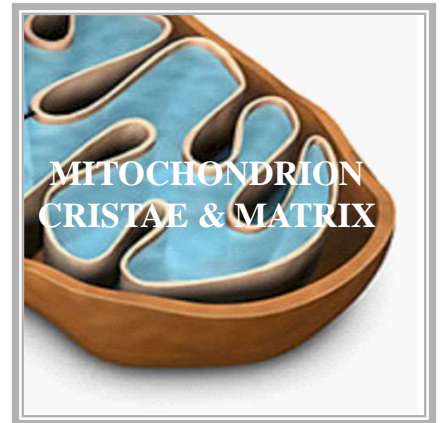

 = ELECTRON TRANSPORT CHAIN COMPONENT

 = HEAT ENERGY

 = CHEMICAL ENERGY



# CHEMIOSMOTIC PHOSPHORYLATION MODEL

MITOCHONDRION CRISTAE SPACE

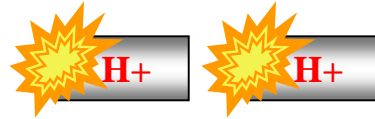

NADH

MITOCHONDRION CRISTAE MEMBRANE

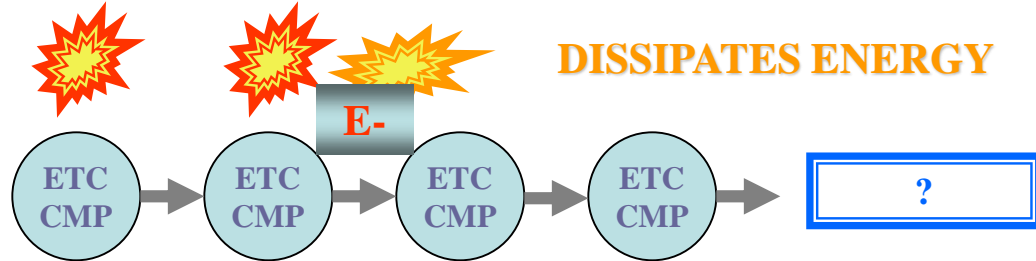

ATP SYNTHASE

H+

H+

MITOCHONDRION MATRIX

● = ELECTRON TRANSPORT CHAIN COMPONENT

★ = HEAT ENERGY

★ = CHEMICAL ENERGY

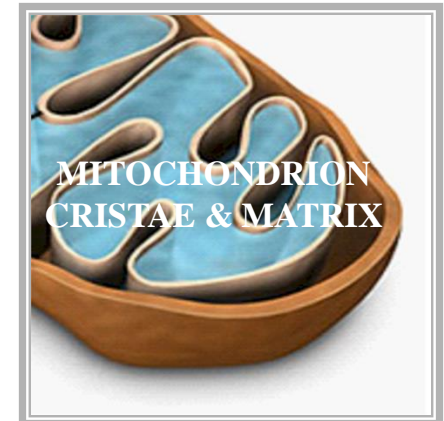

MITOCHONDRION CRISTAE & MATRIX



# CHEMIOSMOTIC PHOSPHORYLATION MODEL

MITOCHONDRION CRISTAE SPACE

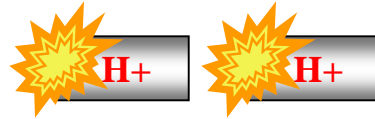

NADH

MITOCHONDRION CRISTAE MEMBRANE

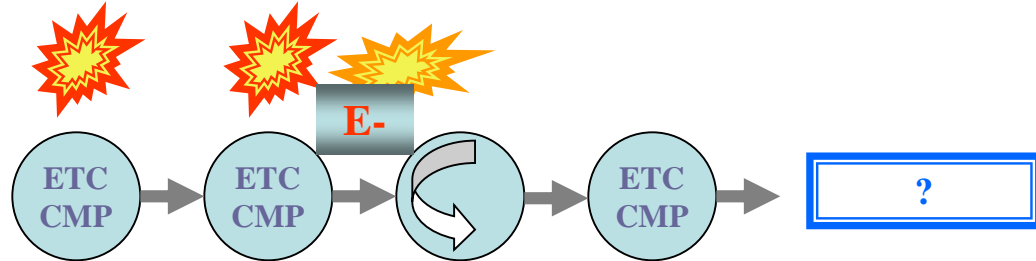

ATP SYNTHASE

H+

H+

MITOCHONDRION MATRIX

 = ELECTRON TRANSPORT CHAIN COMPONENT

 = HEAT ENERGY

 = CHEMICAL ENERGY

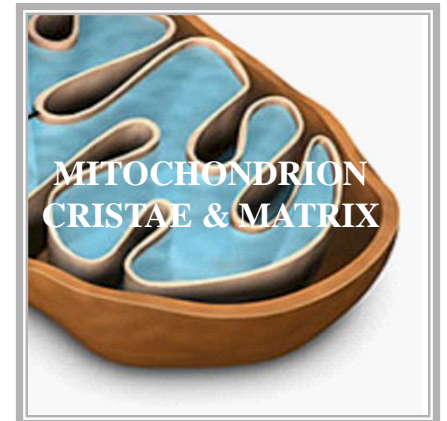

MITOCHONDRION CRISTAE & MATRIX

# CHEMIOSMOTIC PHOSPHORYLATION MODEL

MITOCHONDRION CRISTAE SPACE

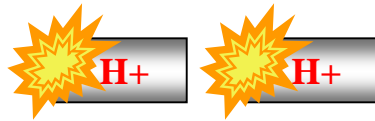

NADH

MITOCHONDRION CRISTAE MEMBRANE

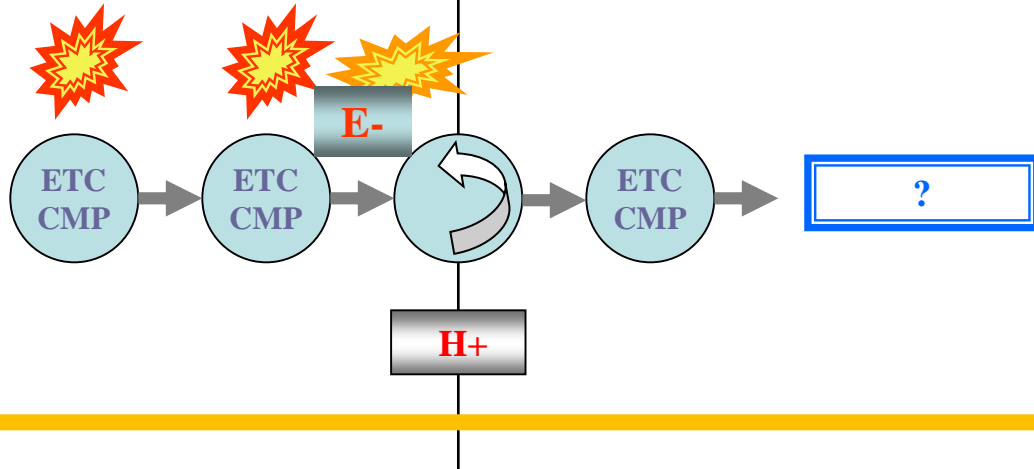

ATP SYNTHASE



MITOCHONDRION MATRIX



 = ELECTRON TRANSPORT CHAIN COMPONENT

 = HEAT ENERGY

 = CHEMICAL ENERGY

# CHEMIOSMOTIC PHOSPHORYLATION MODEL

MITOCHONDRION CRISTAE SPACE



NADH

MITOCHONDRION CRISTAE MEMBRANE

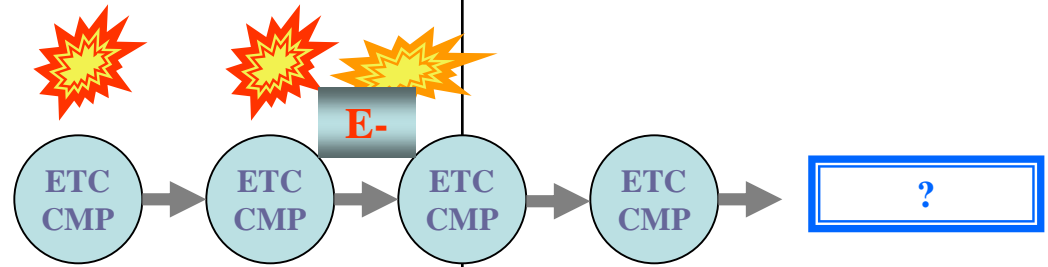

ATP SYNTHASE



MITOCHONDRION MATRIX

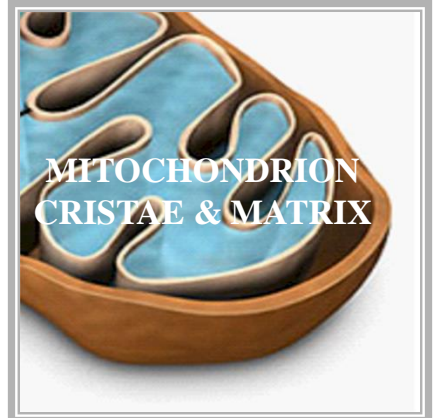

 = ELECTRON TRANSPORT CHAIN COMPONENT

 = HEAT ENERGY

 = CHEMICAL ENERGY

# CHEMIOSMOTIC PHOSPHORYLATION MODEL

MITOCHONDRION CRISTAE SPACE



NADH

MITOCHONDRION CRISTAE MEMBRANE

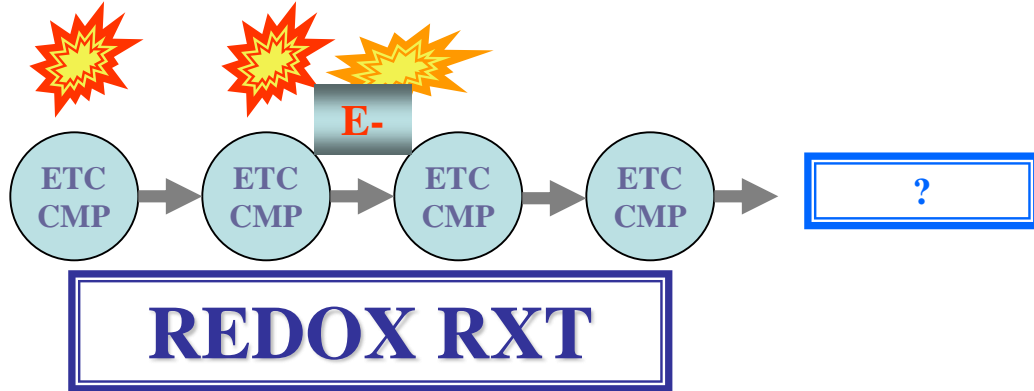

ATP SYNTHASE

H+

MITOCHONDRION MATRIX

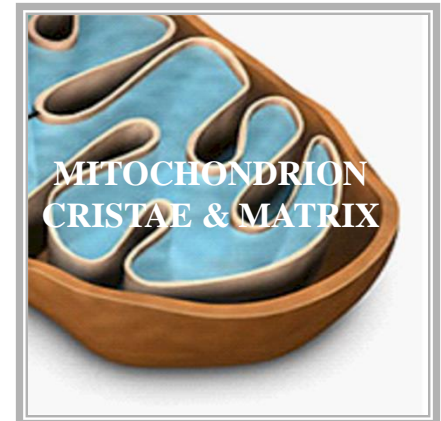

MITOCHONDRION CRISTAE & MATRIX

 = ELECTRON TRANSPORT CHAIN COMPONENT

 = HEAT ENERGY

 = CHEMICAL ENERGY



# CHEMIOSMOTIC PHOSPHORYLATION MODEL

MITOCHONDRION CRISTAE SPACE



NADH

MITOCHONDRION CRISTAE MEMBRANE

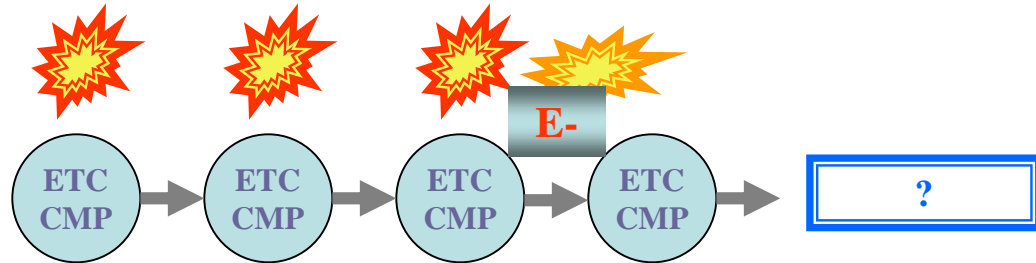

ATP SYNTHASE

H+

MITOCHONDRION MATRIX

● = ELECTRON TRANSPORT CHAIN COMPONENT

★ = HEAT ENERGY

★ = CHEMICAL ENERGY

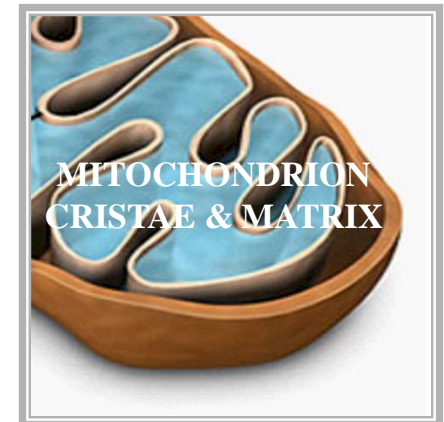



# CHEMIOSMOTIC PHOSPHORYLATION MODEL

MITOCHONDRION CRISTAE SPACE



NADH

MITOCHONDRION CRISTAE MEMBRANE

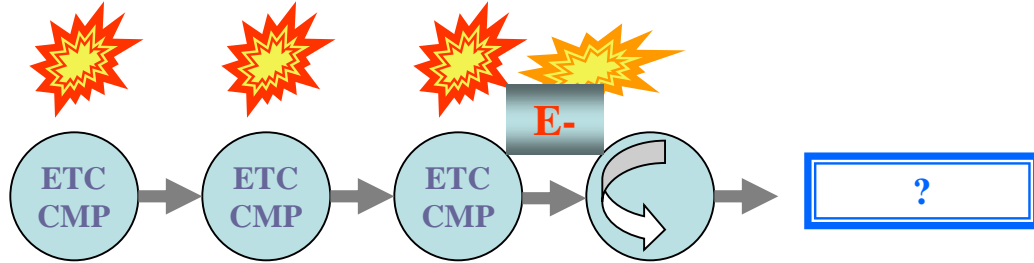

ATP SYNTHASE



MITOCHONDRION MATRIX



● = ELECTRON TRANSPORT CHAIN COMPONENT

★ = HEAT ENERGY

★ = CHEMICAL ENERGY

# CHEMIOSMOTIC PHOSPHORYLATION MODEL

MITOCHONDRION CRISTAE SPACE



NADH

MITOCHONDRION CRISTAE MEMBRANE

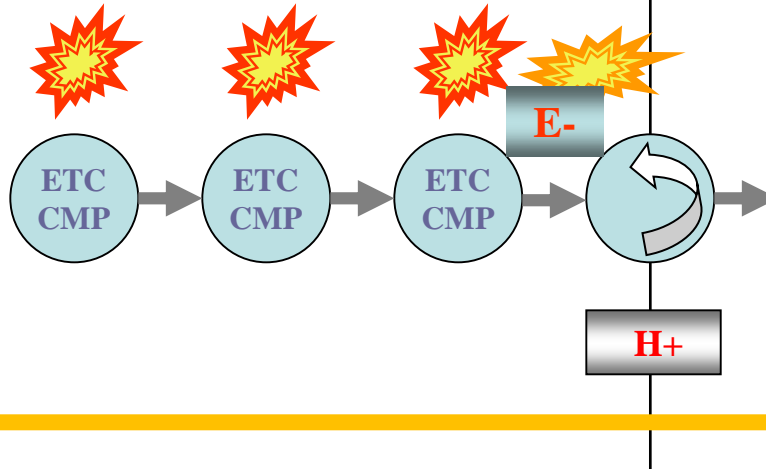

ATP SYNTHASE

MITOCHONDRION MATRIX

 = ELECTRON TRANSPORT CHAIN COMPONENT

 = HEAT ENERGY

 = CHEMICAL ENERGY



# CHEMIOSMOTIC PHOSPHORYLATION MODEL

MITOCHONDRION CRISTAE SPACE

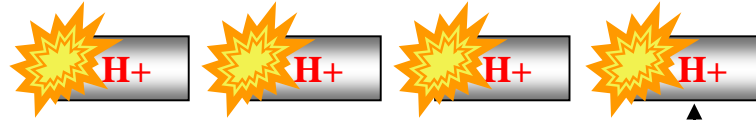

NADH

MITOCHONDRION CRISTAE MEMBRANE

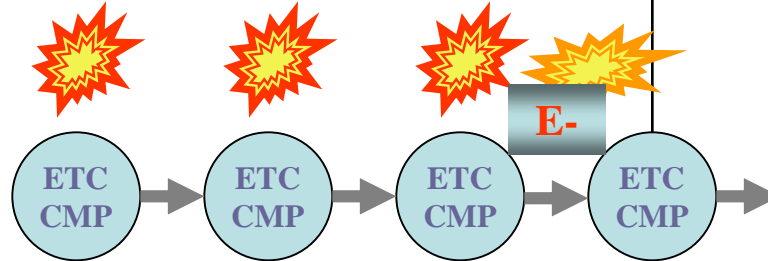

ATP SYNTHASE

MITOCHONDRION MATRIX

● = ELECTRON TRANSPORT CHAIN COMPONENT

★ = HEAT ENERGY

★ = CHEMICAL ENERGY

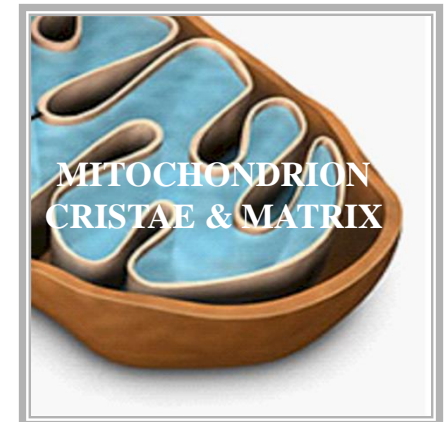

# CHEMIOSMOTIC PHOSPHORYLATION MODEL

MITOCHONDRION CRISTAE SPACE

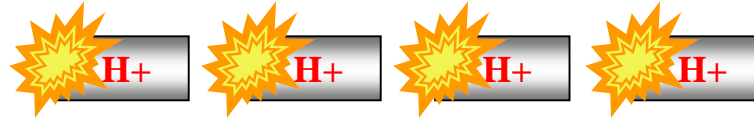

NADH

MITOCHONDRION CRISTAE MEMBRANE

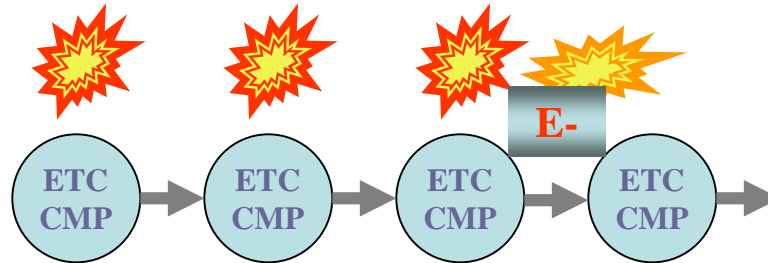

ATP SYNTHASE

REDOX RXT

MITOCHONDRION MATRIX

● = ELECTRON TRANSPORT CHAIN COMPONENT

★ = HEAT ENERGY

★ = CHEMICAL ENERGY

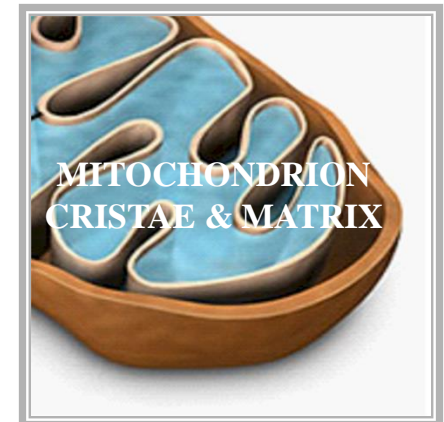

# CHEMIOSMOTIC PHOSPHORYLATION MODEL

MITOCHONDRION CRISTAE SPACE

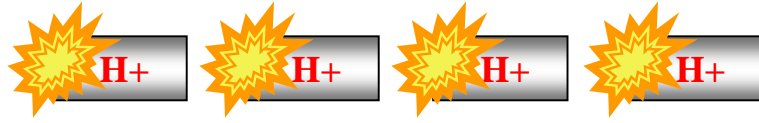

NADH

MITOCHONDRION CRISTAE MEMBRANE

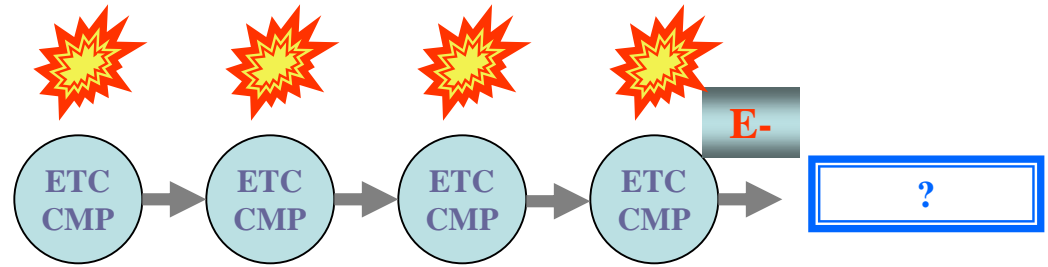

ATP SYNTHASE

MITOCHONDRION MATRIX



 = ELECTRON TRANSPORT CHAIN COMPONENT

 = HEAT ENERGY

 = CHEMICAL ENERGY

# PHOSPHORYLATION

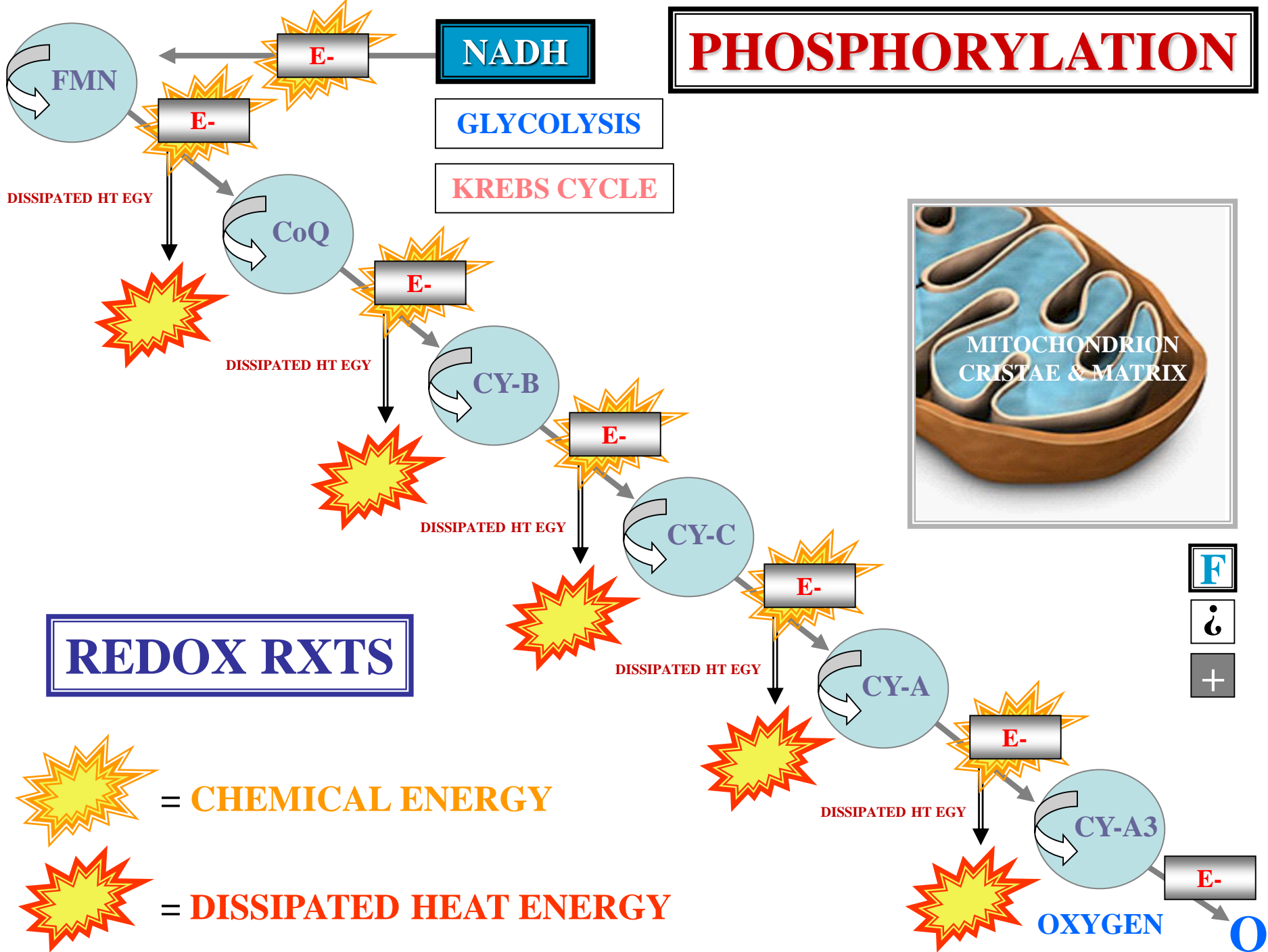



# CHEMIOSMOTIC PHOSPHORYLATION MODEL

MITOCHONDRION CRISTAE SPACE

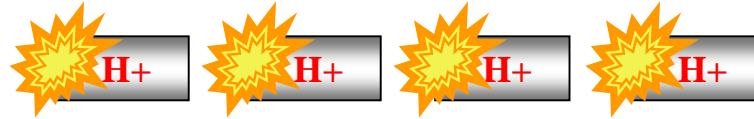

E- DONORS

NADH / FADH

MITOCHONDRION CRISTAE MEMBRANE

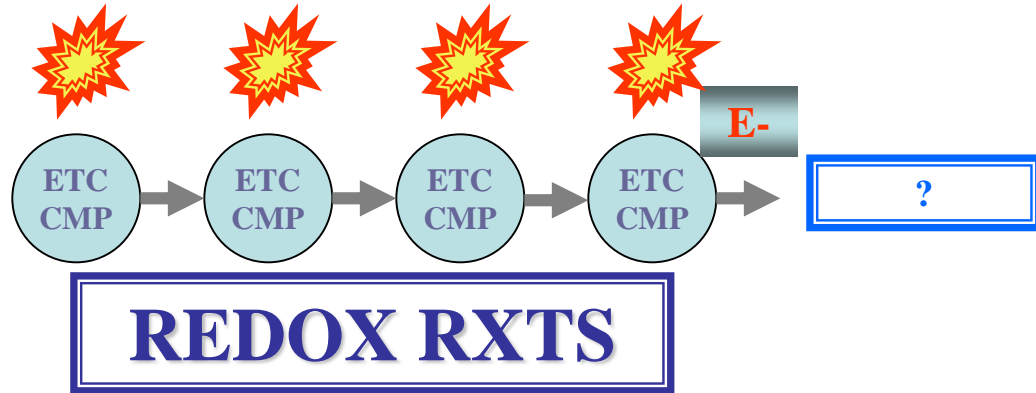

ATP SYNTHASE

MITOCHONDRION MATRIX

● = ELECTRON TRANSPORT CHAIN COMPONENT

★ = HEAT ENERGY

★ = CHEMICAL ENERGY

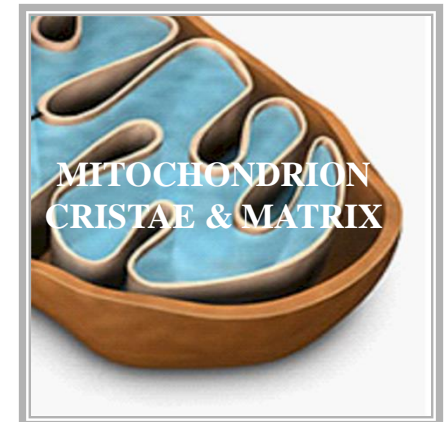



# CHEMIOSMOTIC PHOSPHORYLATION MODEL

MITOCHONDRION CRISTAE SPACE

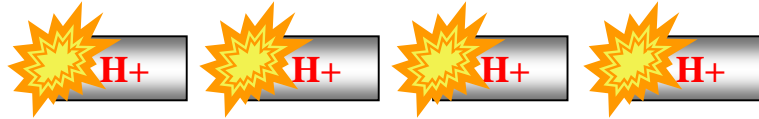

E- DONORS

NADH / FADH

MITOCHONDRION CRISTAE MEMBRANE

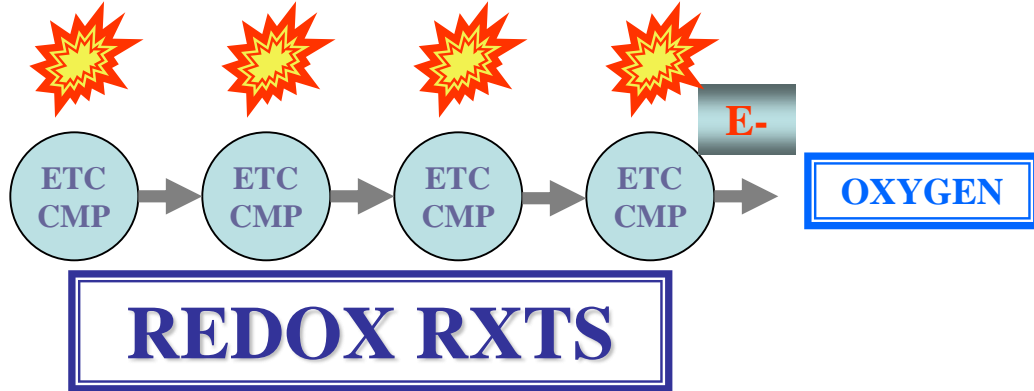

ATP SYNTHASE

MITOCHONDRION MATRIX



● = ELECTRON TRANSPORT CHAIN COMPONENT

★ = HEAT ENERGY

★ = CHEMICAL ENERGY



# OXIDATIVE CHEMIOSMOTIC PHOSPHORYLATION

MITOCHONDRION  
CRISTAE  
SPACE

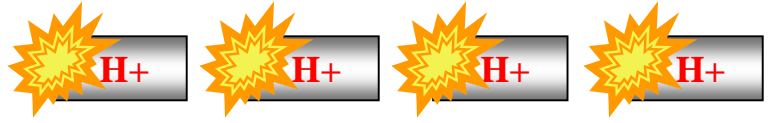

E- DONORS

NADH / FADH

MITOCHONDRION  
CRISTAE  
MEMBRANE

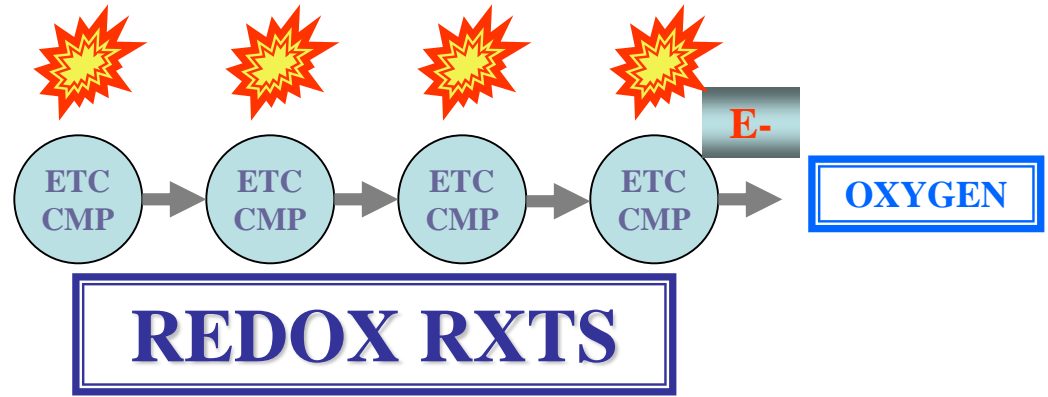

ATP  
SYNTHASE

MITOCHONDRION  
MATRIX



 = ELECTRON TRANSPORT CHAIN COMPONENT

 = HEAT ENERGY

 = CHEMICAL ENERGY



**MITOCHONDRION  
CHEMIOSMOTIC  
PHOSPHORYLATION  
SUMMARY**

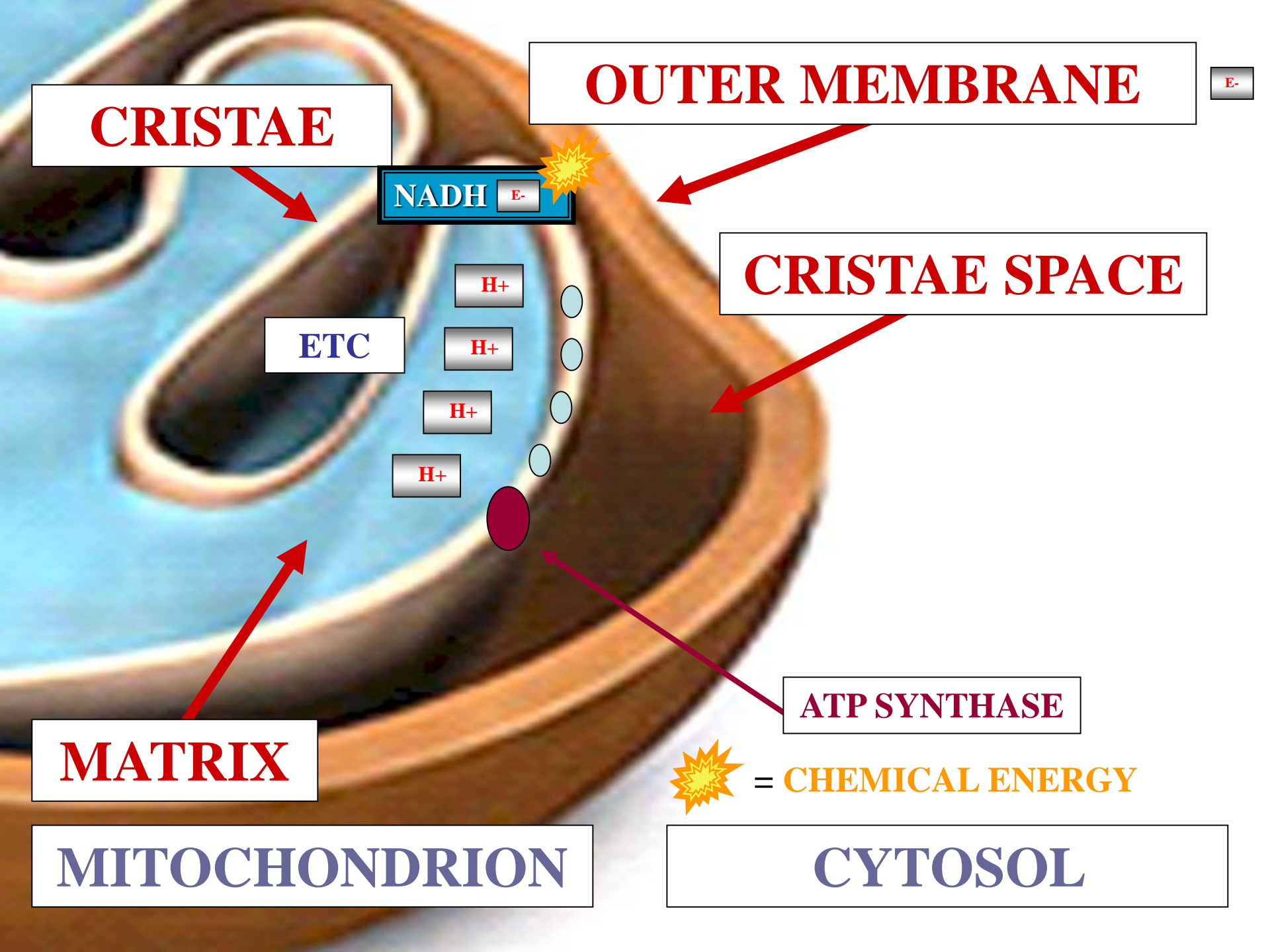

**CRISTAE**

**OUTER MEMBRANE**

$E^-$

**NADH**  $E^-$

**CRISTAE SPACE**

**ETC**

$H^+$

$H^+$

$H^+$

$H^+$

**MATRIX**

**ATP SYNTHASE**

 = **CHEMICAL ENERGY**

**MITOCHONDRION**

**CYTOSOL**

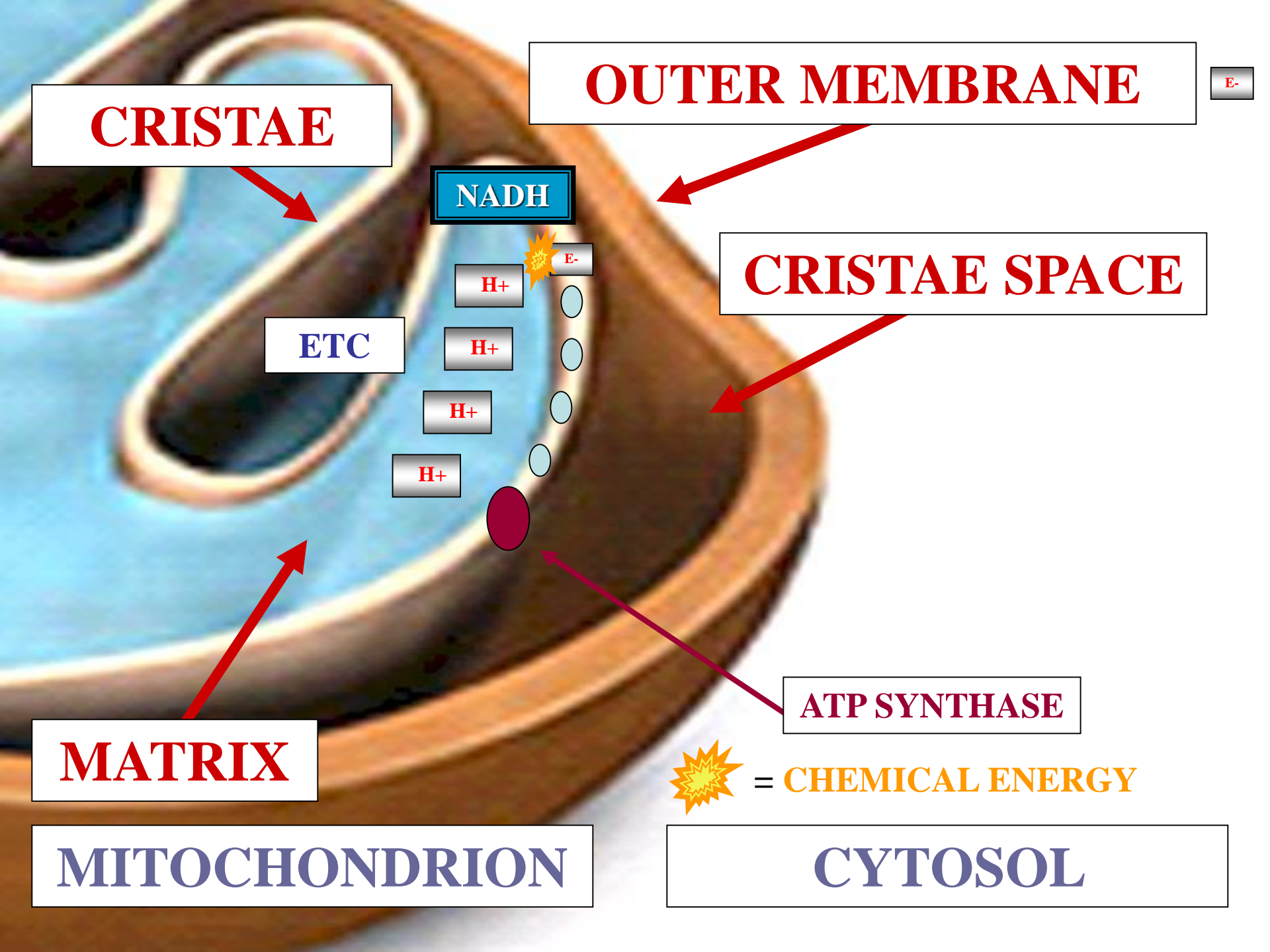

**CRISTAE**

**OUTER MEMBRANE**

**e<sup>-</sup>**

**NADH**

**CRISTAE SPACE**

**ETC**

**H<sup>+</sup>**

**e<sup>-</sup>**

**H<sup>+</sup>**

**H<sup>+</sup>**

**H<sup>+</sup>**

**MATRIX**

**ATP SYNTHASE**



**= CHEMICAL ENERGY**

**MITOCHONDRION**

**CYTOSOL**

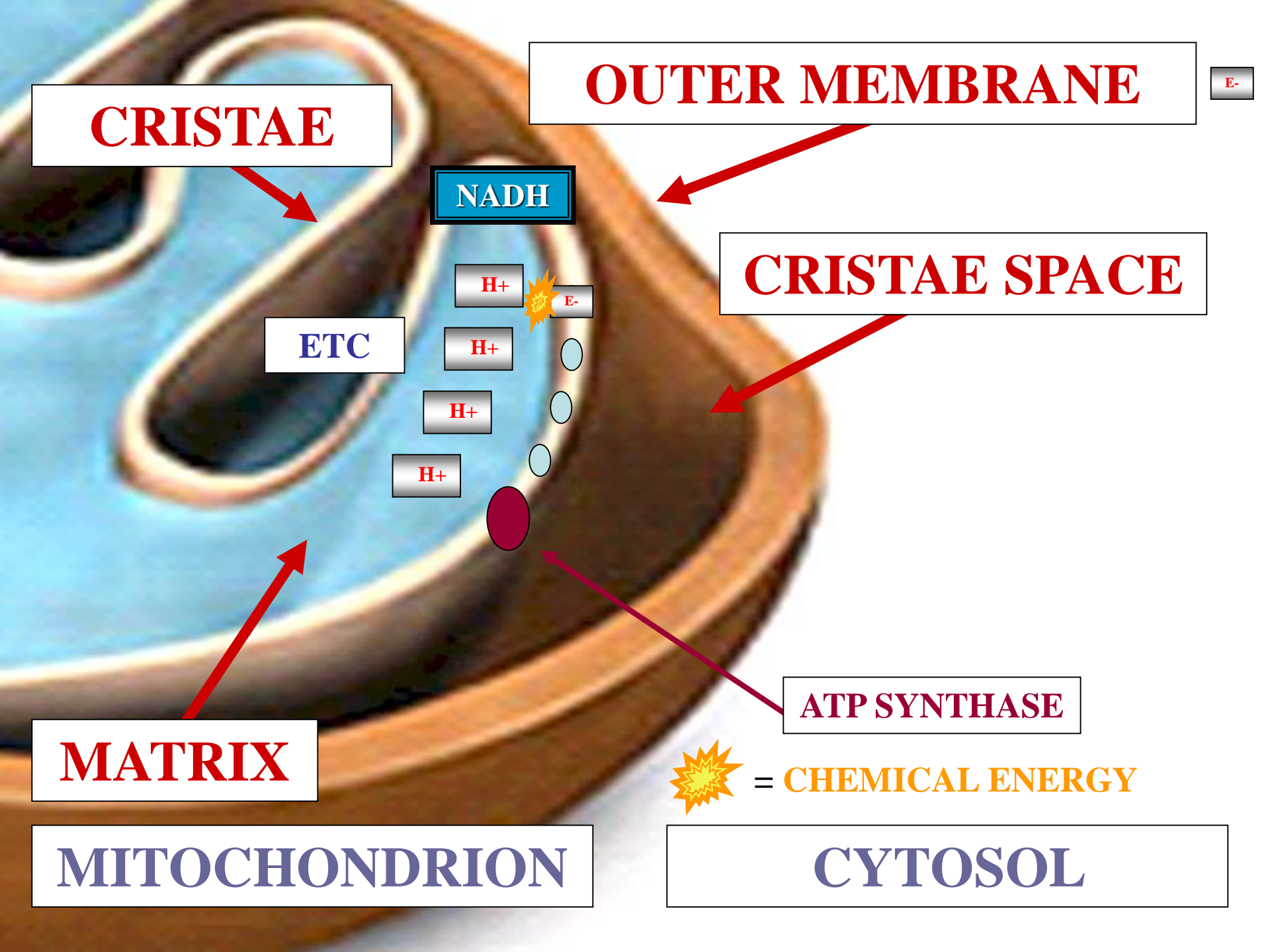

**CRISTAE**

**OUTER MEMBRANE**

$\text{E}^-$

**NADH**

**CRISTAE SPACE**

**ETC**

$\text{H}^+$

$\text{E}^-$

$\text{H}^+$

$\text{H}^+$

$\text{H}^+$

**MATRIX**

**ATP SYNTHASE**



= **CHEMICAL ENERGY**

**MITOCHONDRION**

**CYTOSOL**

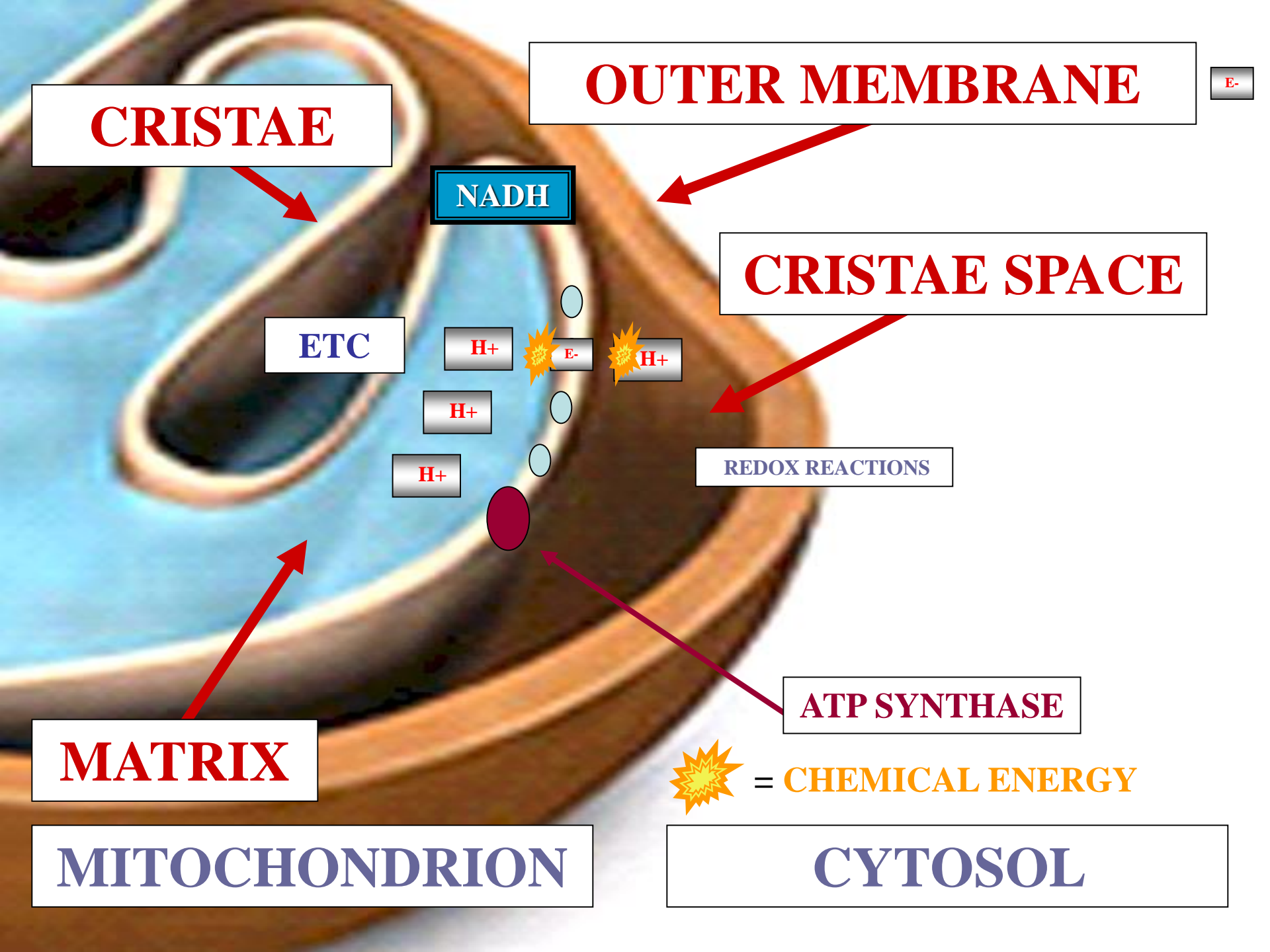

**CRISTAE**

**OUTER MEMBRANE**

$\text{E}^-$

**NADH**

**CRISTAE SPACE**

**ETC**

$\text{H}^+$

$\text{E}^-$

$\text{H}^+$

$\text{H}^+$

**REDOX REACTIONS**

$\text{H}^+$

**MATRIX**

**ATP SYNTHASE**



**= CHEMICAL ENERGY**

**MITOCHONDRION**

**CYTOSOL**

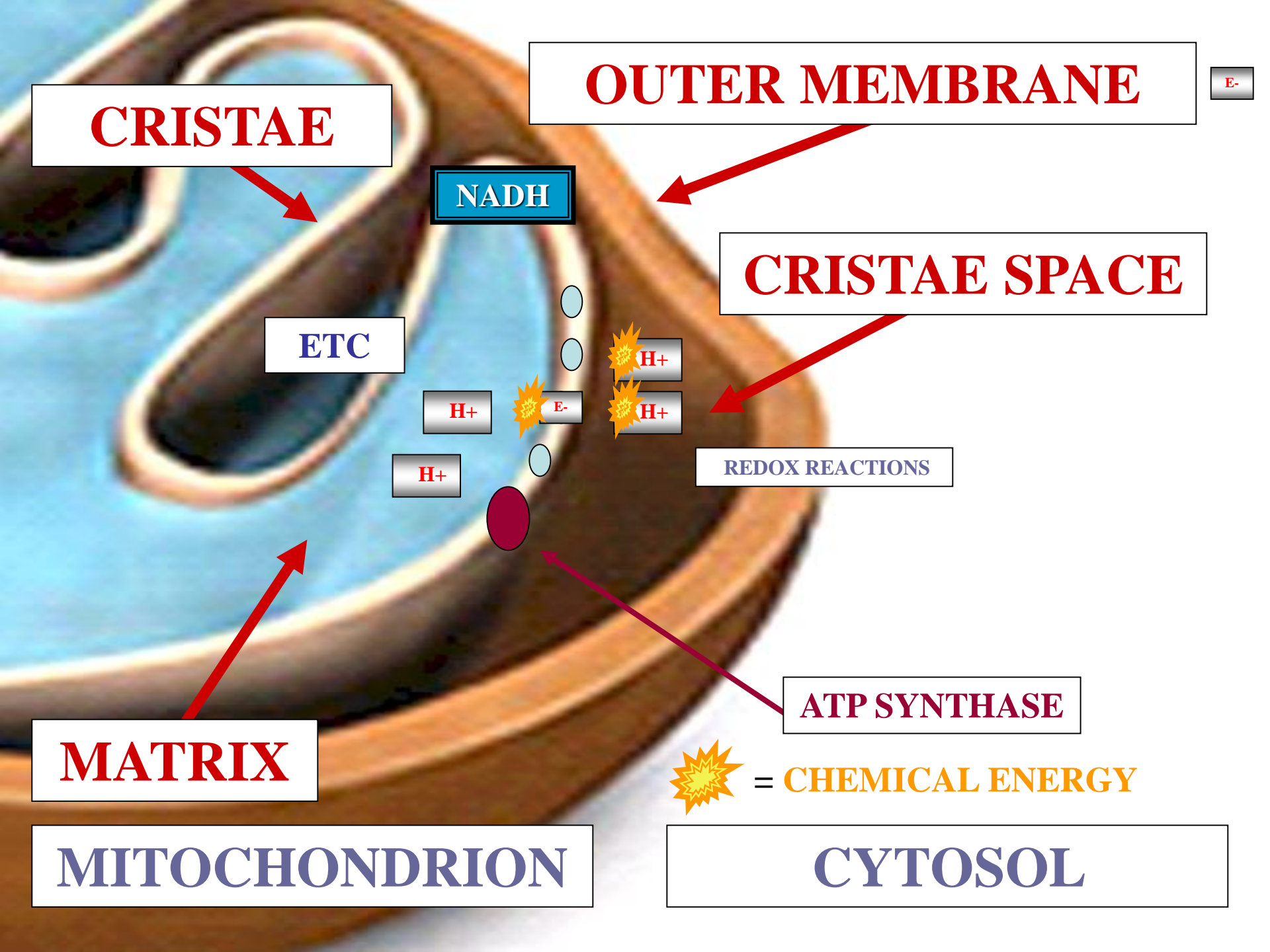

**CRISTAE**

**OUTER MEMBRANE**

E-

**NADH**

**CRISTAE SPACE**

**ETC**

H+

E-

H+

H+

**REDOX REACTIONS**

H+

**ATP SYNTHASE**

**MATRIX**

**= CHEMICAL ENERGY**

**MITOCHONDRION**

**CYTOSOL**



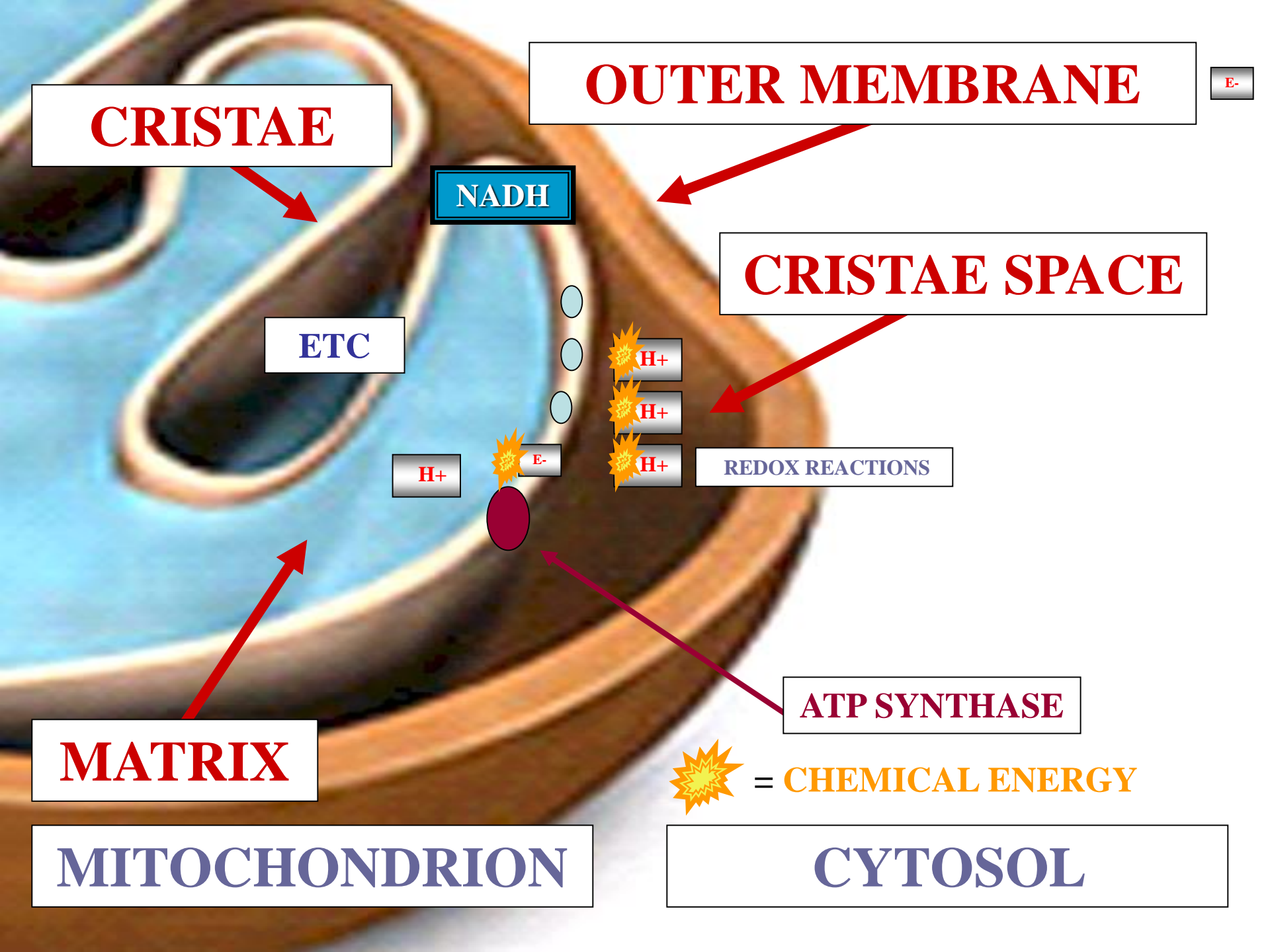

**CRISTAE**

**OUTER MEMBRANE**

**E-**

**NADH**

**CRISTAE SPACE**

**ETC**

**H+**  
**H+**  
**H+**

**REDOX REACTIONS**

**H+**

**E-**

**ATP SYNTHASE**

**MATRIX**

**CHEMICAL ENERGY**

**MITOCHONDRION**

**CYTOSOL**

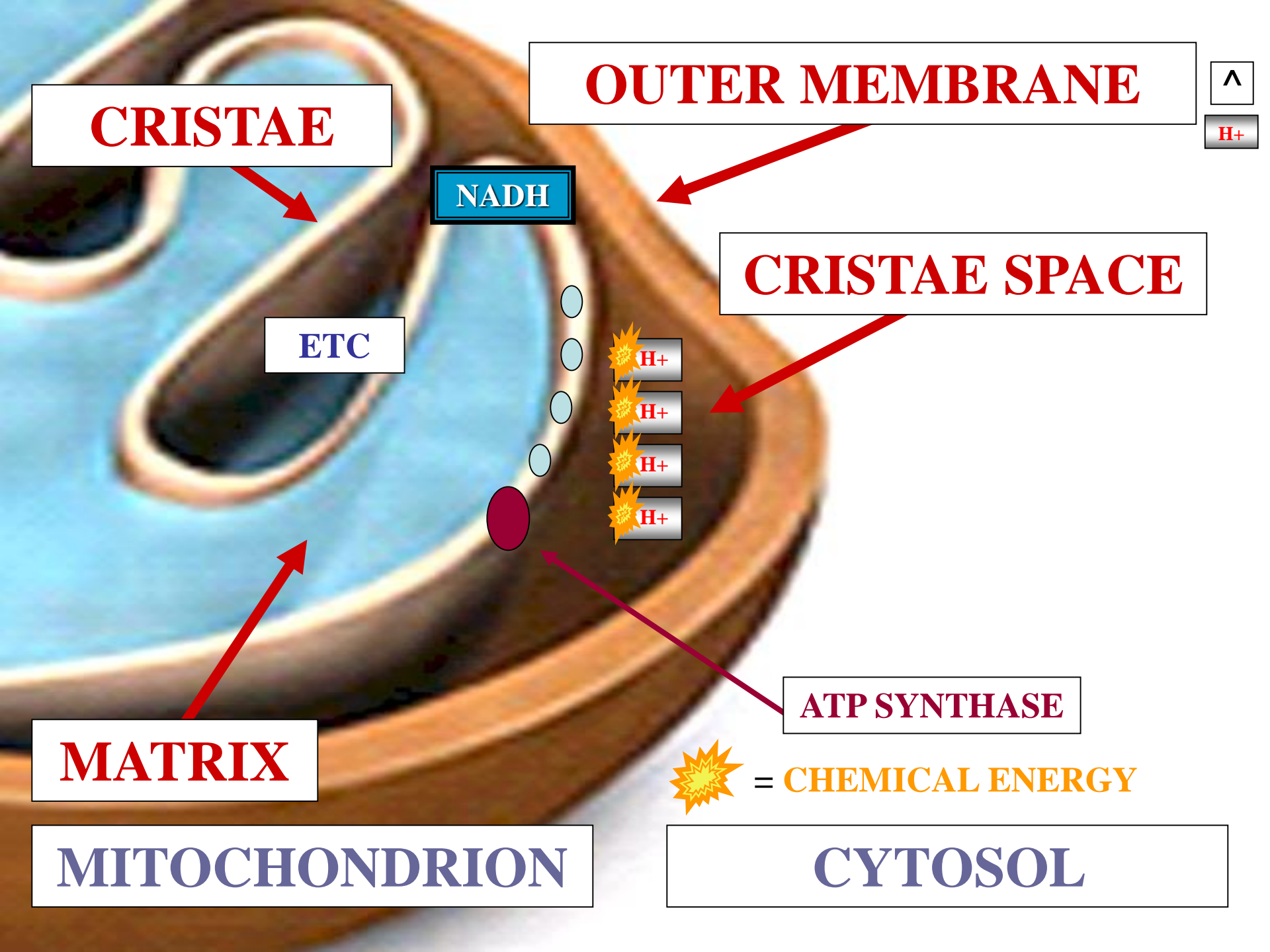

A

MITOCHONDRION  
CRISTAE  
SPACE

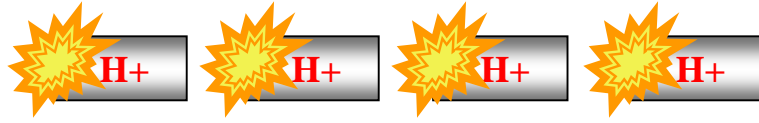
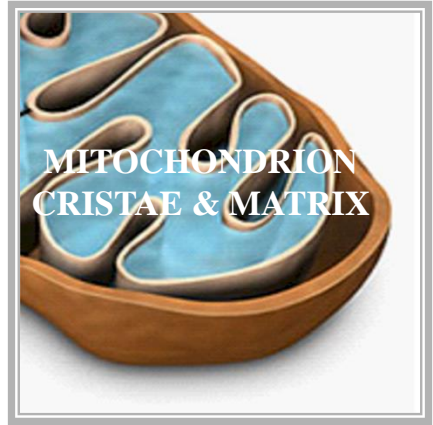

NADH

MITOCHONDRION  
CRISTAE  
MEMBRANE

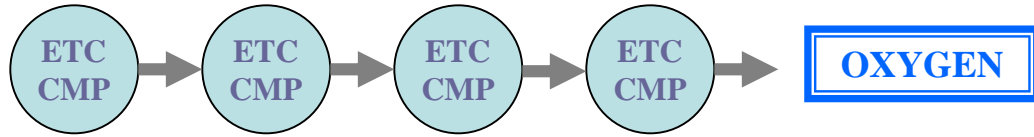

ATP  
SYNTHASE

MITOCHONDRION  
MATRIX

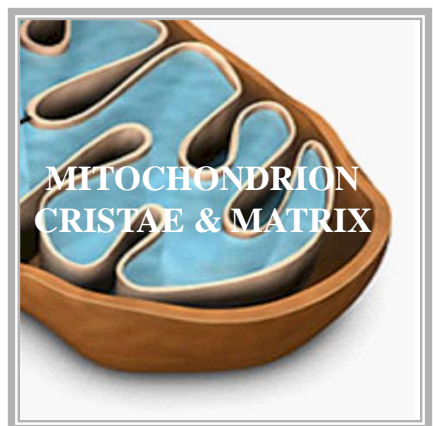

● = ELECTRON TRANSPORT CHAIN COMPONENT

★ = HEAT ENERGY

★ = CHEMICAL ENERGY

**P**

# H+ ACCUMULATE BEHIND ATP-SYNTASE

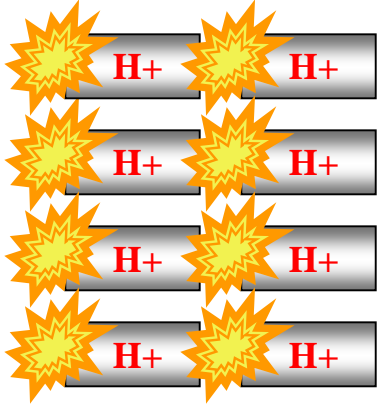

**MITOCHONDRION  
CRISTAE  
SPACE**

**NADH**

**MITOCHONDRION  
CRISTAE  
MEMBRANE**

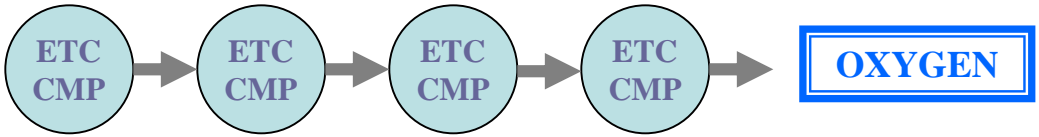

**ATP  
SYNTASE**

**MITOCHONDRION  
MATRIX**



 = ELECTRON TRANSPORT CHAIN COMPONENT

 = HEAT ENERGY

 = CHEMICAL ENERGY



# H<sup>+</sup> ACCUMULATE BEHIND ATP-SYNTHASE

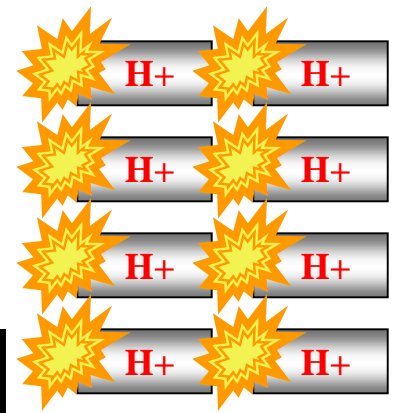

MITOCHONDRION  
CRISTAE  
SPACE

POTENTIAL CHEM EGY

NADH

MITOCHONDRION  
CRISTAE  
MEMBRANE

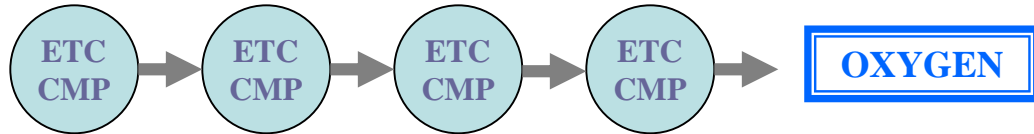

ATP  
SYNTHASE

MITOCHONDRION  
MATRIX

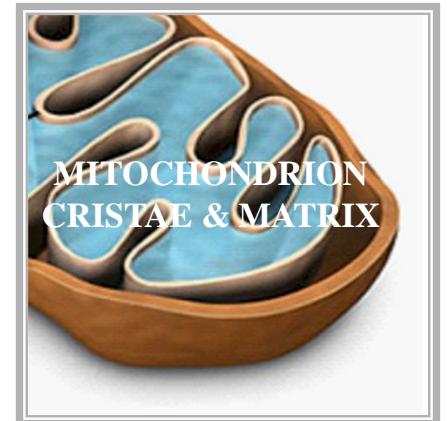

 = ELECTRON TRANSPORT CHAIN COMPONENT

 = HEAT ENERGY

 = CHEMICAL ENERGY



**MITOCHONDRION  
CRISTAE  
SPACE**

# ANALOGY WATER & DAM

**POTENTIAL CHEM EGY**

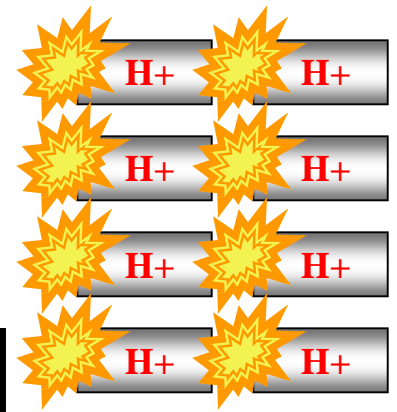

**NADH**

**MITOCHONDRION  
CRISTAE  
MEMBRANE**

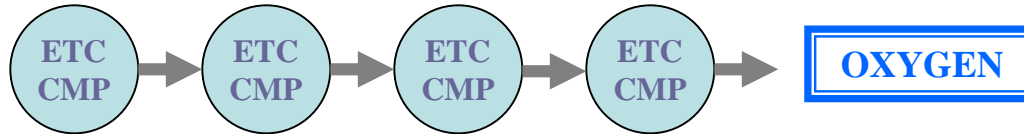

**ATP  
SYNTHASE**

**MITOCHONDRION  
MATRIX**

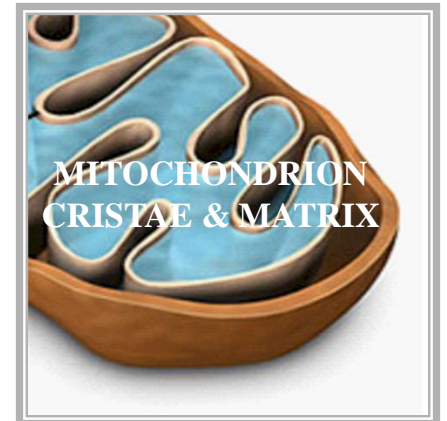

 = **ELECTRON TRANSPORT CHAIN COMPONENT**

 = **HEAT ENERGY**

 = **CHEMICAL ENERGY**



# ANALOGY WATER & DAM

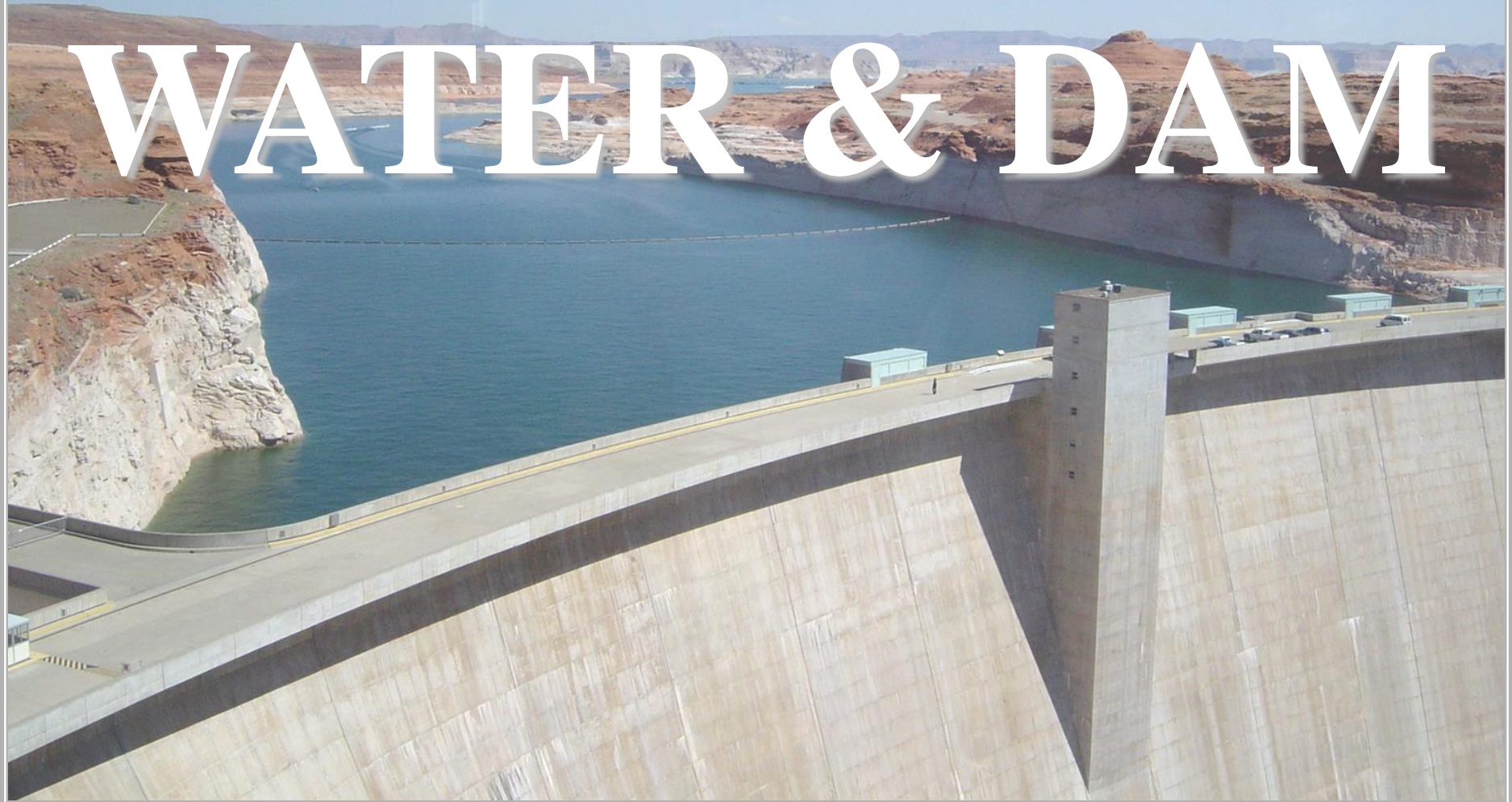

**WATER = ?**

**H**





**WATER = H<sup>+</sup>**

**WATER = H<sup>+</sup>**

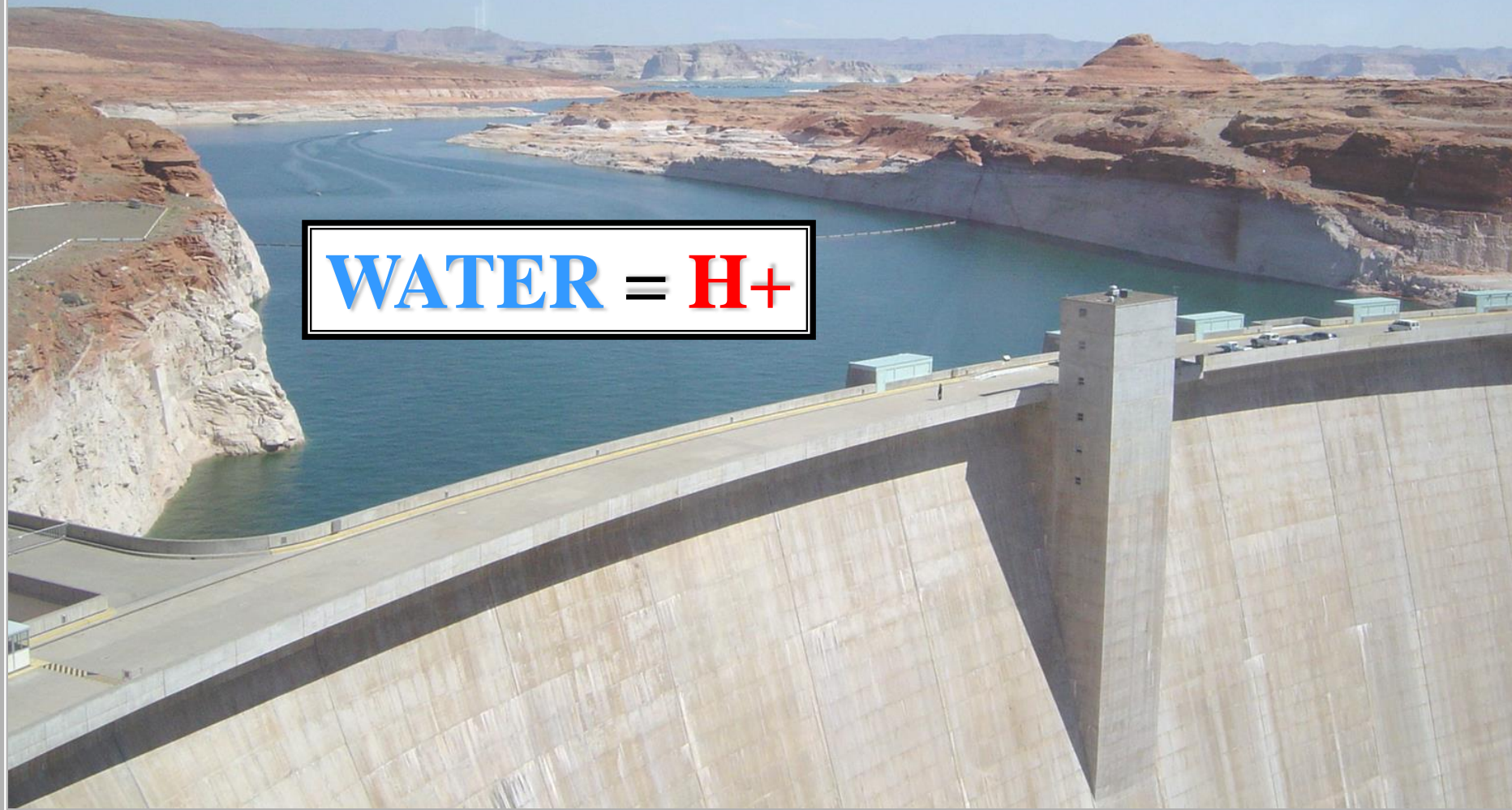

**WATER = H<sup>+</sup>**

!

DB

**DAM = ATP-SYNTHASE**

**WATER = H<sup>+</sup>**

**DAM = ATP-SYNTHASE**

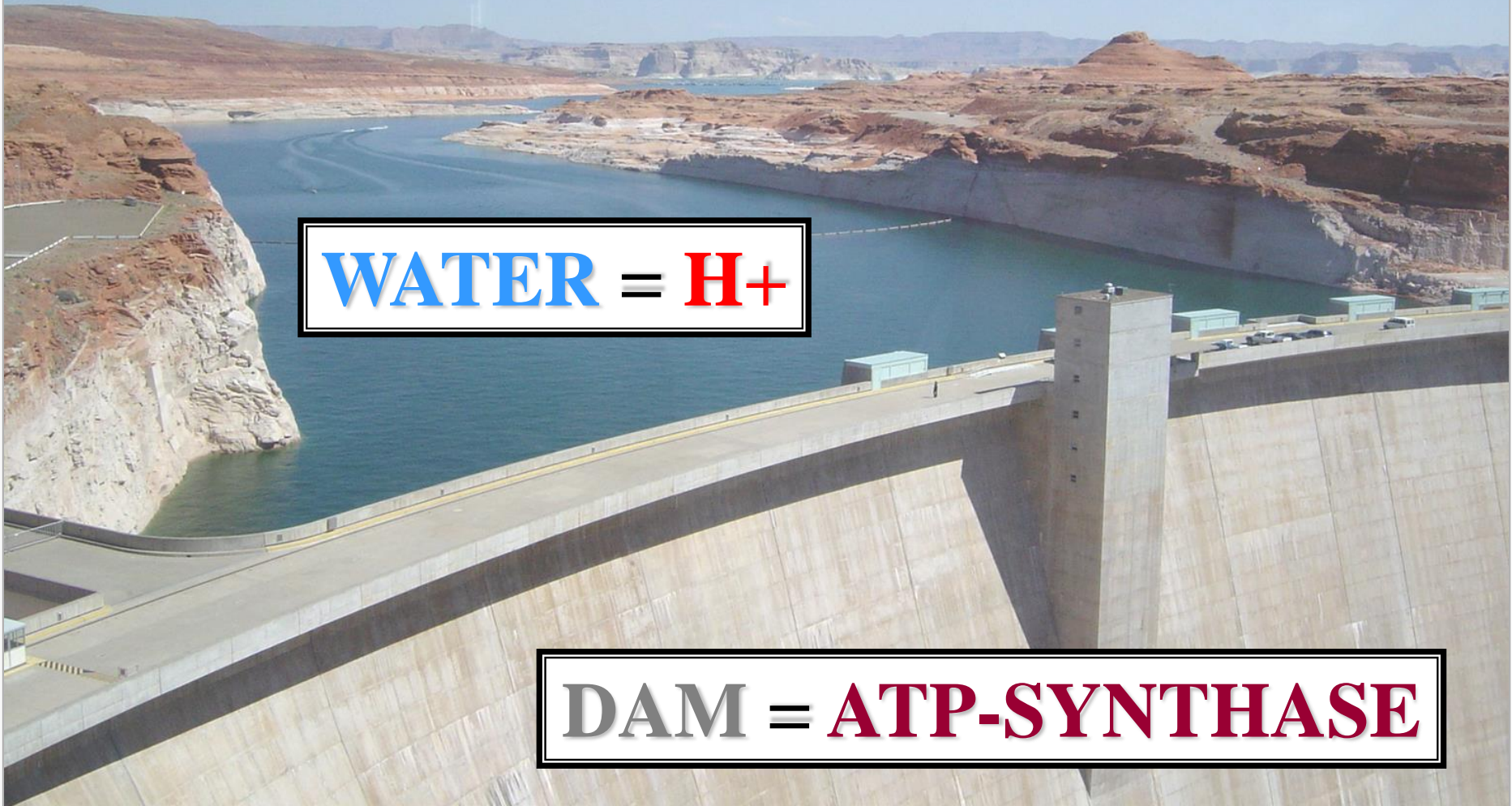



MITOCHONDRION  
CRISTAE  
SPACE

# CRITICAL MASS H<sup>+</sup> PASS VIA ATP SYNTHASE TO MATRIX

POTENTIAL CHEM EGY

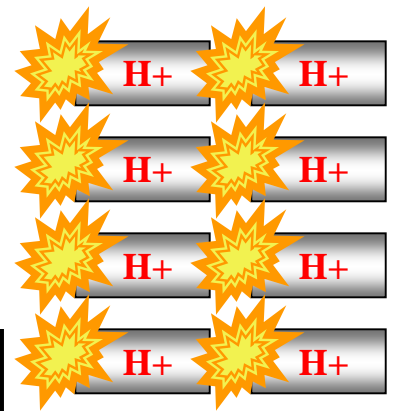

NADH

MITOCHONDRION  
CRISTAE  
MEMBRANE

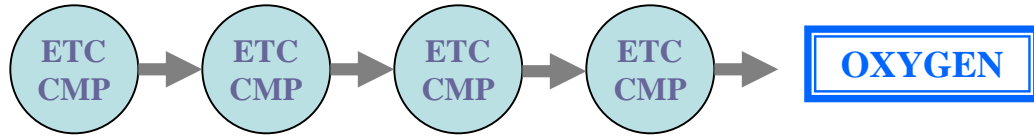

ATP  
SYNTHASE

MITOCHONDRION  
MATRIX

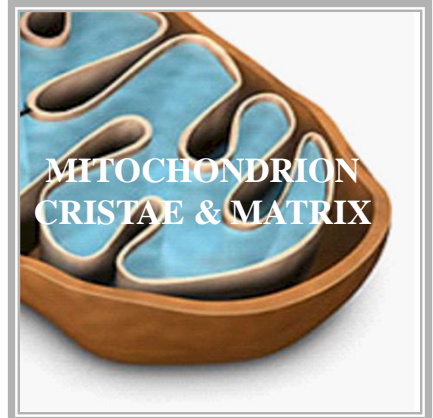

 = ELECTRON TRANSPORT CHAIN COMPONENT

 = HEAT ENERGY

 = CHEMICAL ENERGY



# CRITICAL MASS

## H<sup>+</sup> PASS VIA ATP SYNTHASE TO MATRIX

MITOCHONDRION  
CRISTAE  
SPACE

POTENTIAL CHEM EGY

NADH

MITOCHONDRION  
CRISTAE  
MEMBRANE

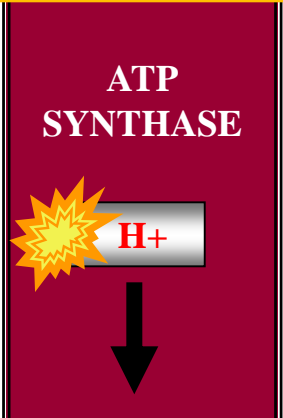
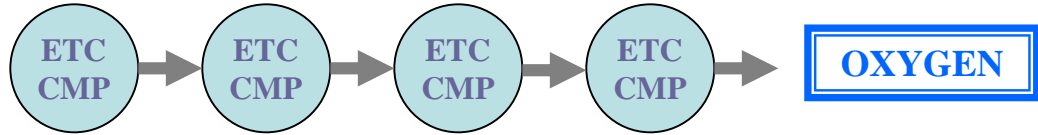

MITOCHONDRION  
MATRIX



 = ELECTRON TRANSPORT CHAIN COMPONENT

 = HEAT ENERGY

 = CHEMICAL ENERGY



# CRITICAL MASS

## H+ PASS VIA ATP SYNTHASE TO MATRIX

MITOCHONDRION CRISTAE SPACE

POTENTIAL CHEM EGY

NADH

MITOCHONDRION CRISTAE MEMBRANE

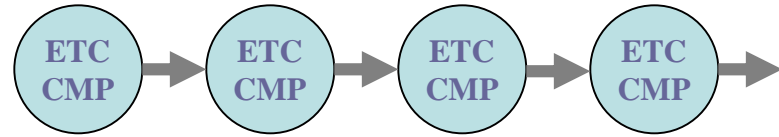

OXYGEN

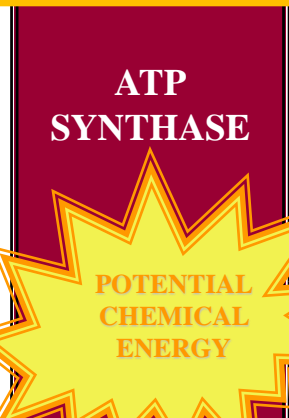

MITOCHONDRION MATRIX

 = ELECTRON TRANSPORT CHAIN COMPONENT

 = HEAT ENERGY

 = CHEMICAL ENERGY

**EX**

**MITOCHONDRION  
CRISTAE  
SPACE**



**NADH**

**MITOCHONDRION  
CRISTAE  
MEMBRANE**

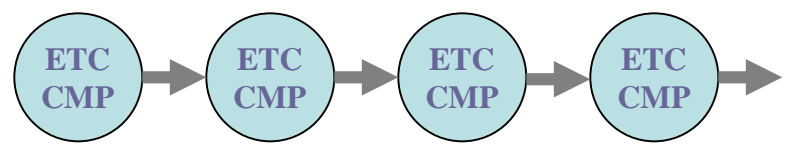

**OXYGEN**

**ATP  
SYNTHASE**

**POTENTIAL CHEM EGY RELEASED**



**MITOCHONDRION  
MATRIX**

 = **ELECTRON TRANSPORT CHAIN COMPONENT**

 = **HEAT ENERGY**

 = **CHEMICAL ENERGY**

**A**

**MITOCHONDRION  
CRISTAE  
SPACE**



**NADH**

**MITOCHONDRION  
CRISTAE  
MEMBRANE**

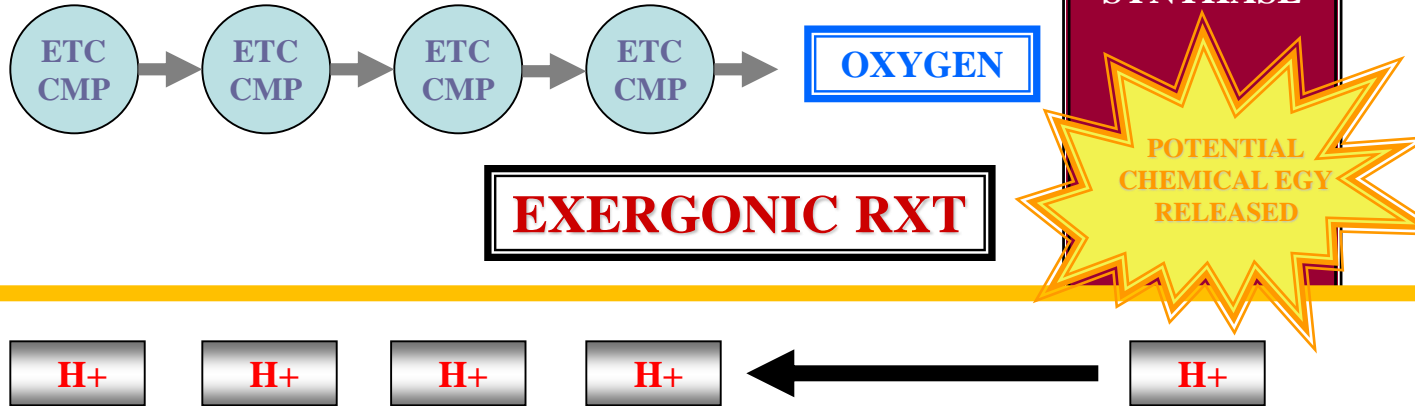

**MITOCHONDRION  
MATRIX**

 = ELECTRON TRANSPORT CHAIN COMPONENT

 = HEAT ENERGY

 = CHEMICAL ENERGY

**I**

**MITOCHONDRION  
CRISTAE  
SPACE**



**NADH**

**MITOCHONDRION  
CRISTAE  
MEMBRANE**

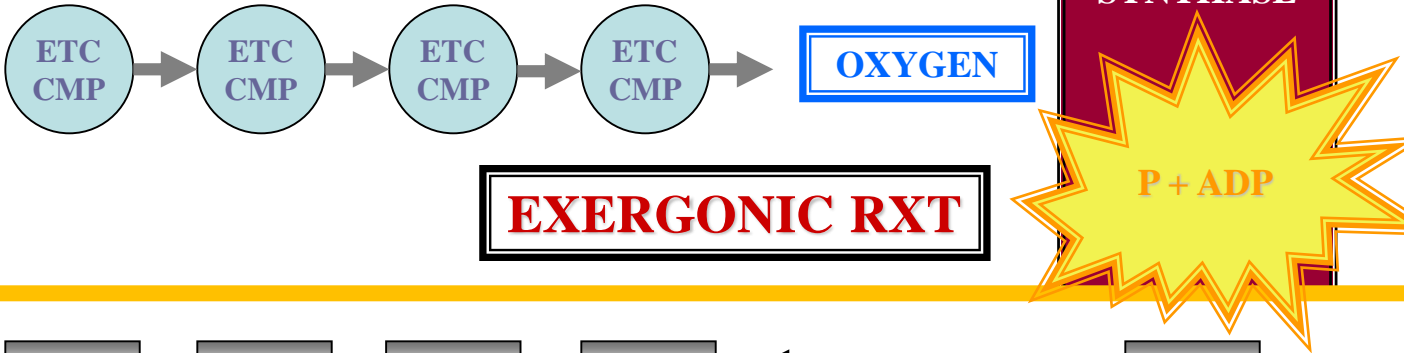

**MITOCHONDRION  
MATRIX**

 = ELECTRON TRANSPORT CHAIN COMPONENT

 = HEAT ENERGY

 = CHEMICAL ENERGY



**A**

**MITOCHONDRION  
CRISTAE  
SPACE**



**NADH**

**MITOCHONDRION  
CRISTAE  
MEMBRANE**

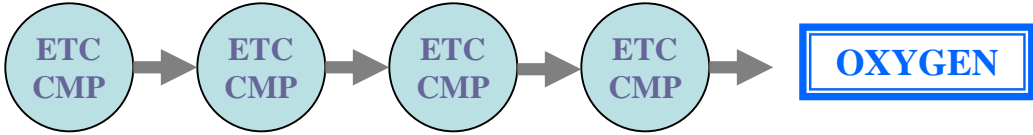

**EXERGONIC RXT**

**ATP  
SYNTHASE**

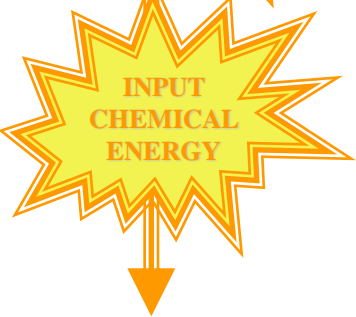

**?**

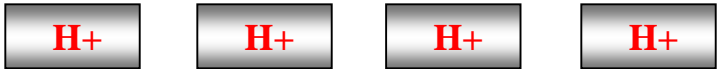

**MITOCHONDRION  
MATRIX**

● = **ELECTRON TRANSPORT CHAIN COMPONENT**

★ = **HEAT ENERGY**

★ = **CHEMICAL ENERGY**

**EN**

**MITOCHONDRION  
CRISTAE  
SPACE**



**NADH**

**MITOCHONDRION  
CRISTAE  
MEMBRANE**

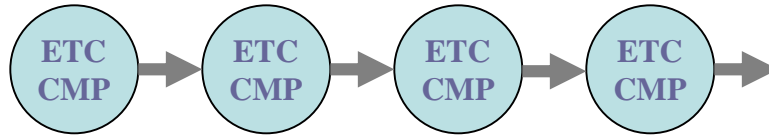

**OXYGEN**

**EXERGONIC RXT**

**ATP  
SYNTHASE**

**P + ADP**

**H+**

**H+**

**H+**

**H+**

**MITOCHONDRION  
MATRIX**

**INPUT  
CHEMICAL  
ENERGY**

**ATP**

 = **ELECTRON TRANSPORT CHAIN COMPONENT**

 = **HEAT ENERGY**

 = **CHEMICAL ENERGY**

C

MITOCHONDRION  
CRISTAE  
SPACE



MITOCHONDRION  
CRISTAE & MATRIX

NADH

MITOCHONDRION  
CRISTAE  
MEMBRANE

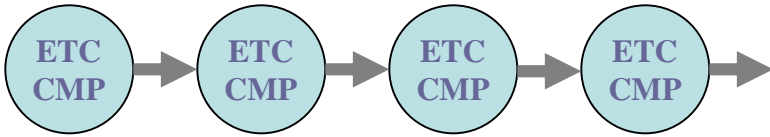

OXYGEN

EXERGONIC RXT

ATP  
SYNTHASE

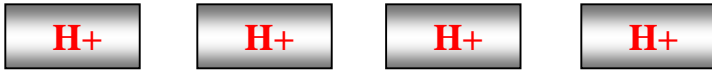

ENDERGONIC RXT

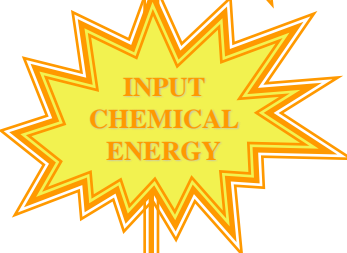

MITOCHONDRION  
MATRIX

ATP

● = ELECTRON TRANSPORT CHAIN COMPONENT

★ = HEAT ENERGY

★ = CHEMICAL ENERGY

**P**

**MITOCHONDRION  
CRISTAE  
SPACE**



**NADH**

**MITOCHONDRION  
CRISTAE  
MEMBRANE**

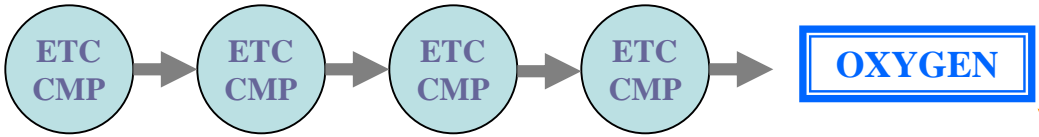

**EXERGONIC RXT**

**ATP  
SYNTHASE**



**ENDERGONIC RXT**

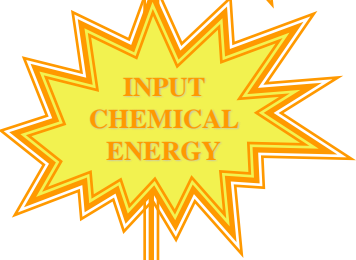

**MITOCHONDRION  
MATRIX**

**ATP**

● = **ELECTRON TRANSPORT CHAIN COMPONENT**

★ = **HEAT ENERGY**

★ = **CHEMICAL ENERGY**

\$



MITOCHONDRION CRISTAE SPACE

NADH  
MITOCHONDRION CRISTAE MEMBRANE

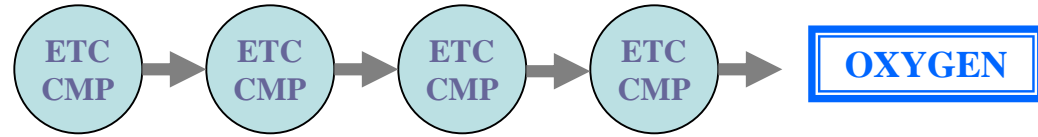

EXERGONIC RXT

ATP SYNTHASE  
P + ADP



ENDERGONIC RXT

MITOCHONDRION MATRIX

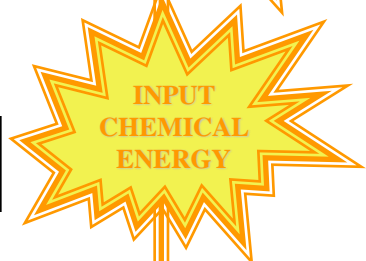

PHOSPHORYLATION

A large, detailed illustration of a mitochondrion, showing its characteristic bean-like shape and internal membrane folds called cristae. The outer membrane is a dark brown color, while the inner membrane is a lighter, golden-brown color. The space between the membranes is filled with a light blue, granular substance representing the matrix. The mitochondrion is shown in a three-quarter view, giving it a 3D appearance.

# MITOCHONDRION CHEMIOSMOTIC PHOSPHORYLATION SUMMARY

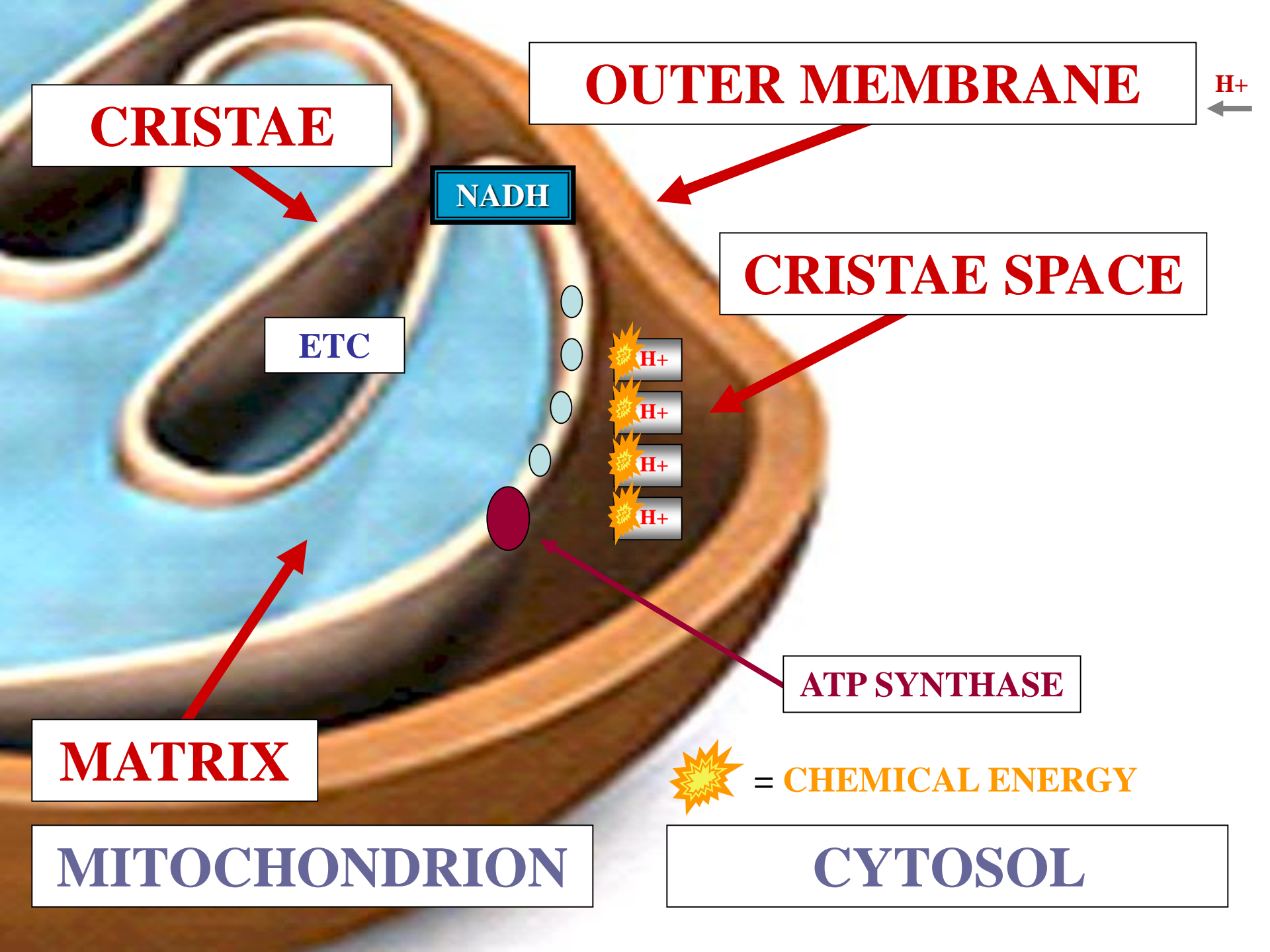





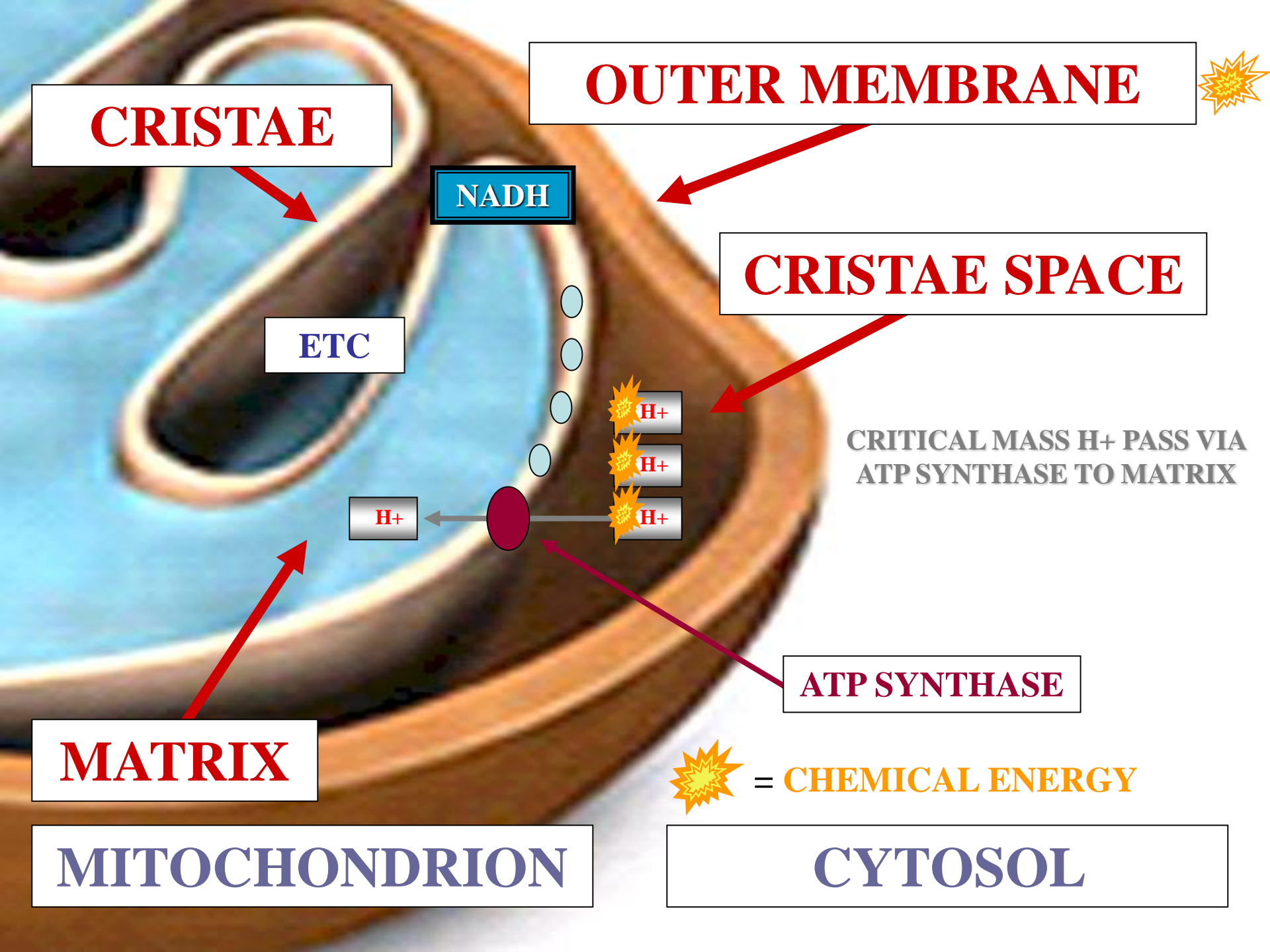

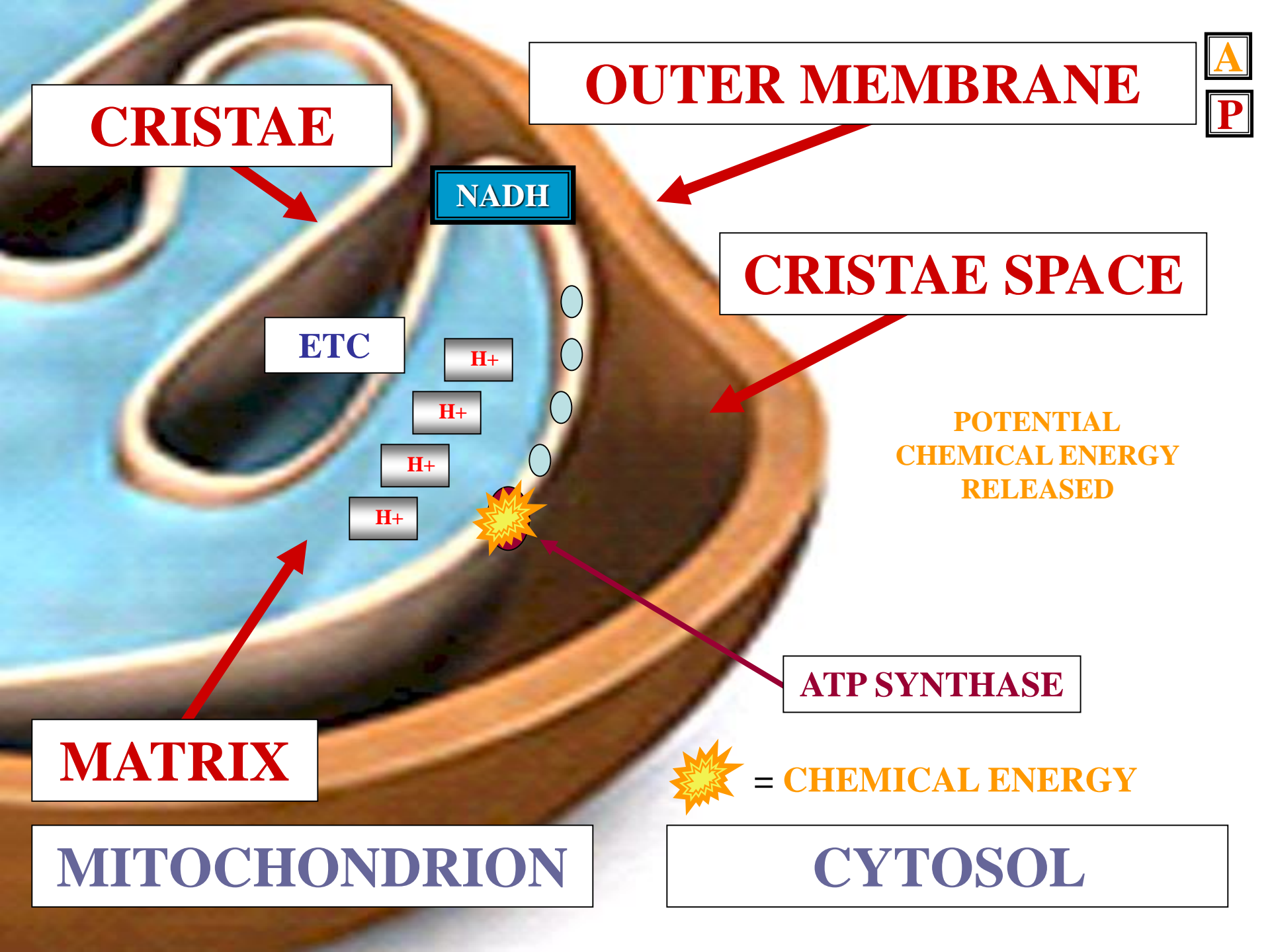

A  
P

**CRISTAE**

**OUTER MEMBRANE**

**NADH**

**CRISTAE SPACE**

**ETC**

**H<sup>+</sup>**

**H<sup>+</sup>**

**H<sup>+</sup>**

**H<sup>+</sup>**

**POTENTIAL  
CHEMICAL ENERGY  
RELEASED**

**ATP SYNTHASE**

**MATRIX**

**★ = CHEMICAL ENERGY**

**MITOCHONDRION**

**CYTOSOL**

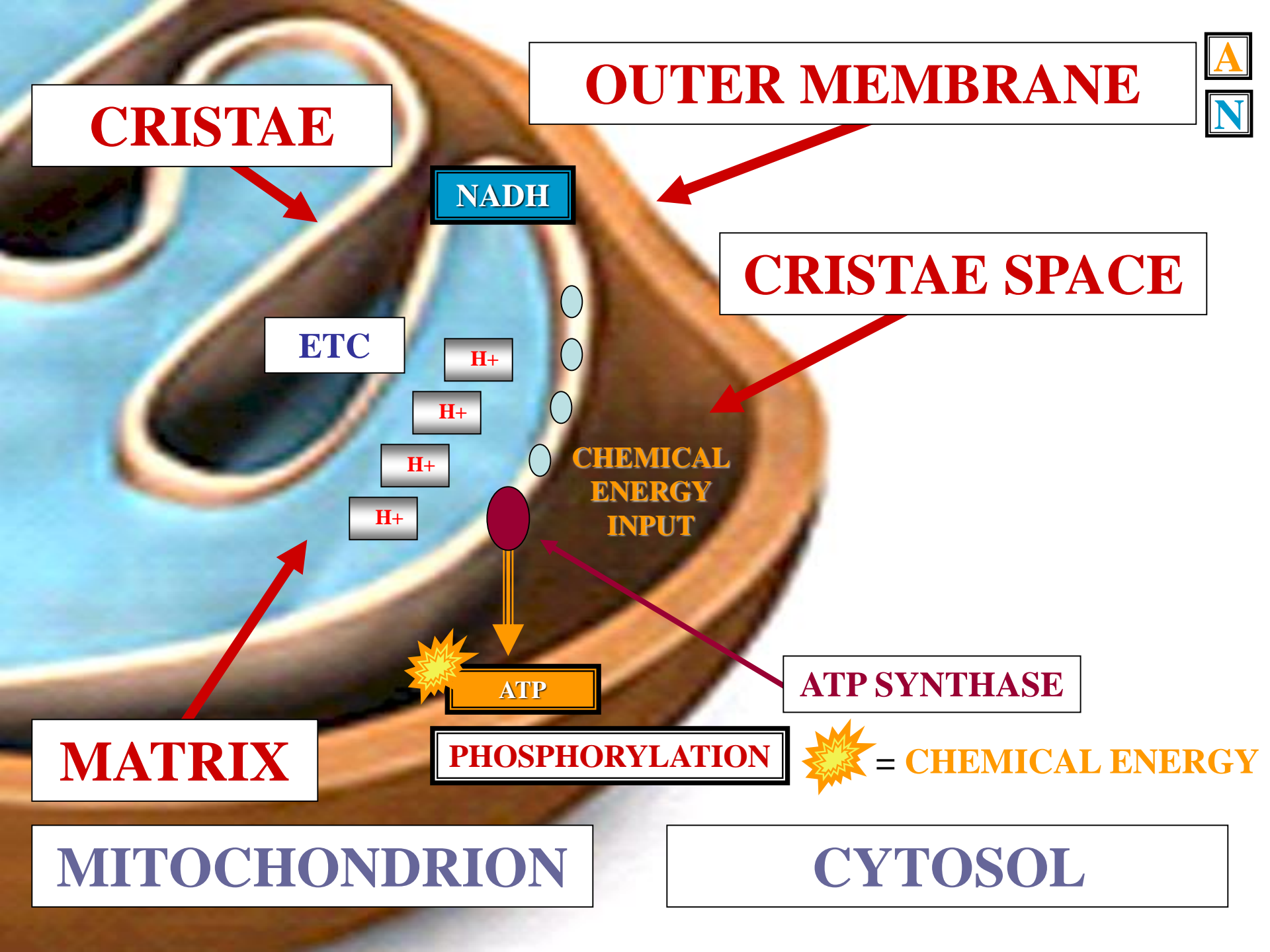

**CRISTAE**

**OUTER MEMBRANE**

**CRISTAE SPACE**

**ETC**

**NADH**

**H<sup>+</sup>**

**H<sup>+</sup>**

**H<sup>+</sup>**

**H<sup>+</sup>**

**CHEMICAL ENERGY INPUT**

**ATP SYNTHASE**

**ATP**

**PHOSPHORYLATION**

**MATRIX**

**MITOCHONDRION**

**CYTOSOL**

**☆ = CHEMICAL ENERGY**



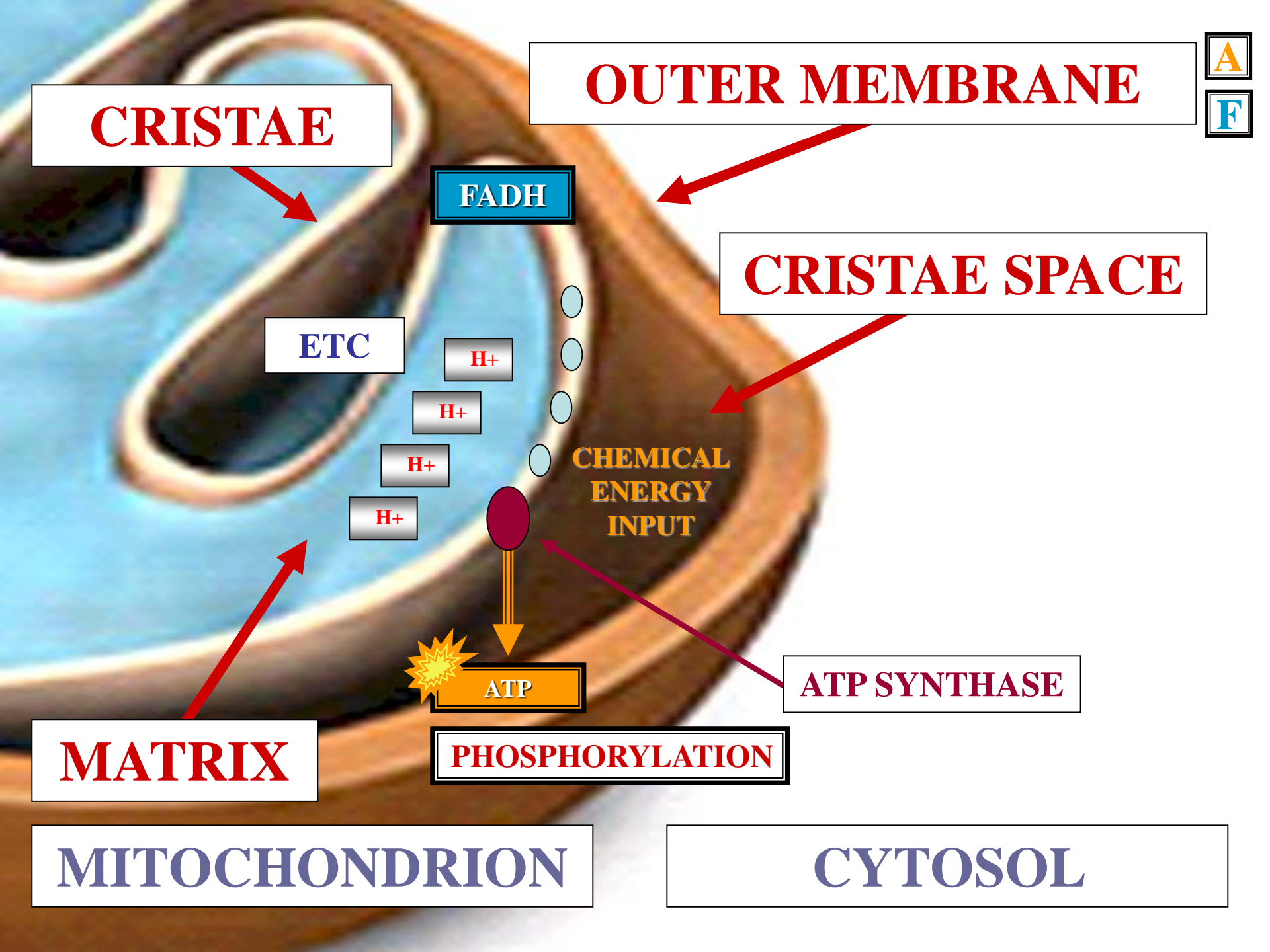

A  
F

**OUTER MEMBRANE**

**CRISTAE**

**FADH**

**CRISTAE SPACE**

**ETC**

**H<sup>+</sup>**

**H<sup>+</sup>**

**H<sup>+</sup>**

**H<sup>+</sup>**

**CHEMICAL  
ENERGY  
INPUT**

**ATP SYNTHASE**

**ATP**

**MATRIX**

**PHOSPHORYLATION**

**MITOCHONDRION**

**CYTOSOL**

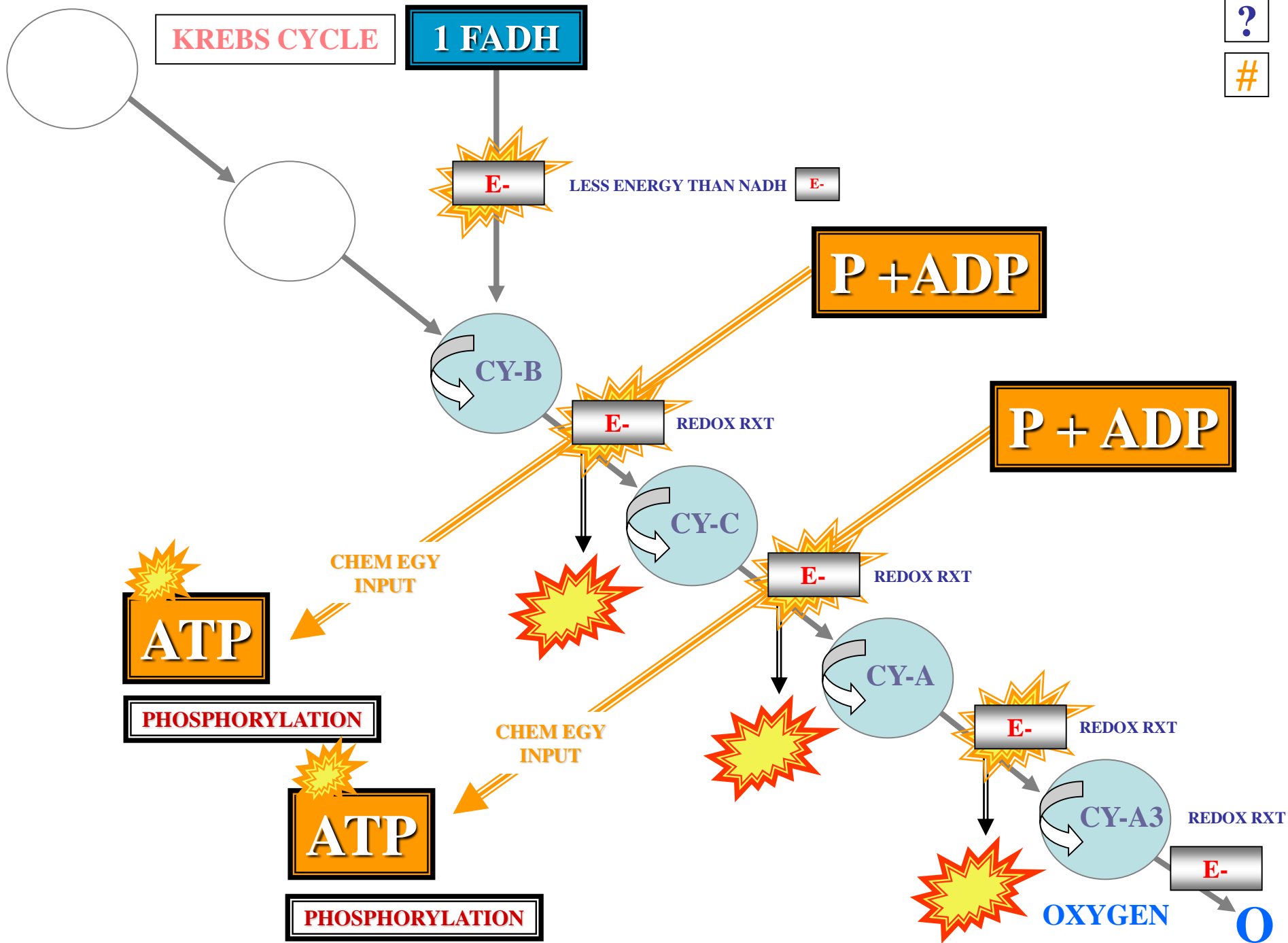

**QUESTION**

**HOW MANY NET ATP  
VIA  
E- TRANSPORT CHAIN**

**QUESTION**

# AEROBIC RESPIRATION

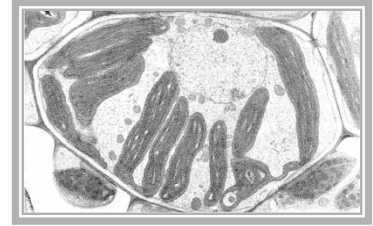

C  
?

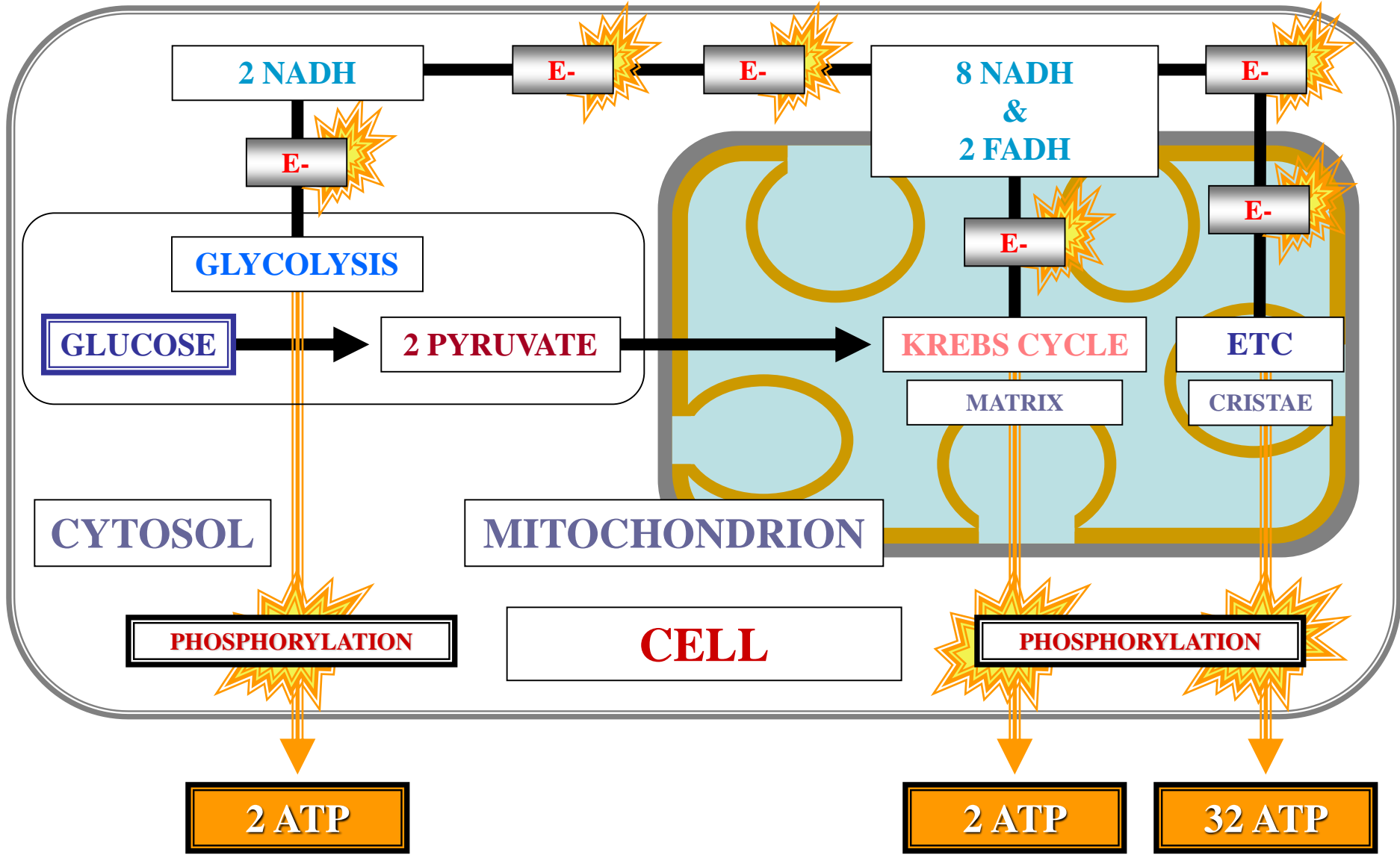



# CHEMIOSMOTIC PHOSPHORYLATION MODEL

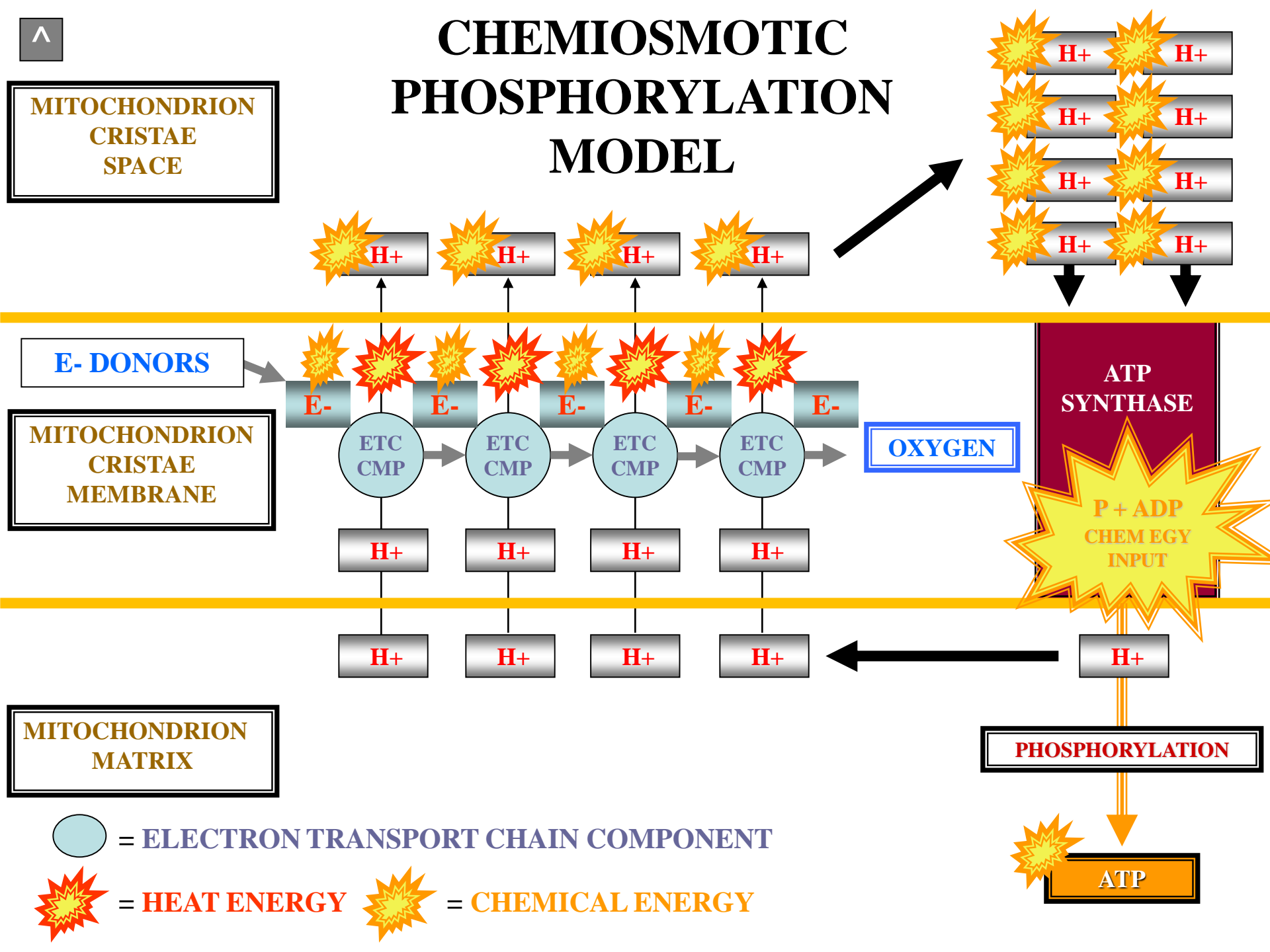



# **AEROBIC RESPIRATION SUMMARY**

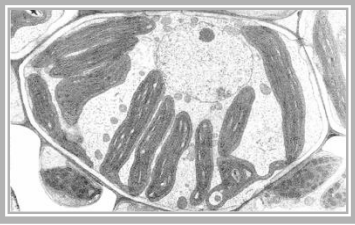

# AEROBIC RESPIRATION

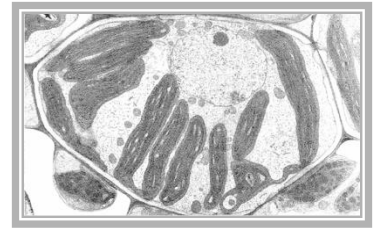

G

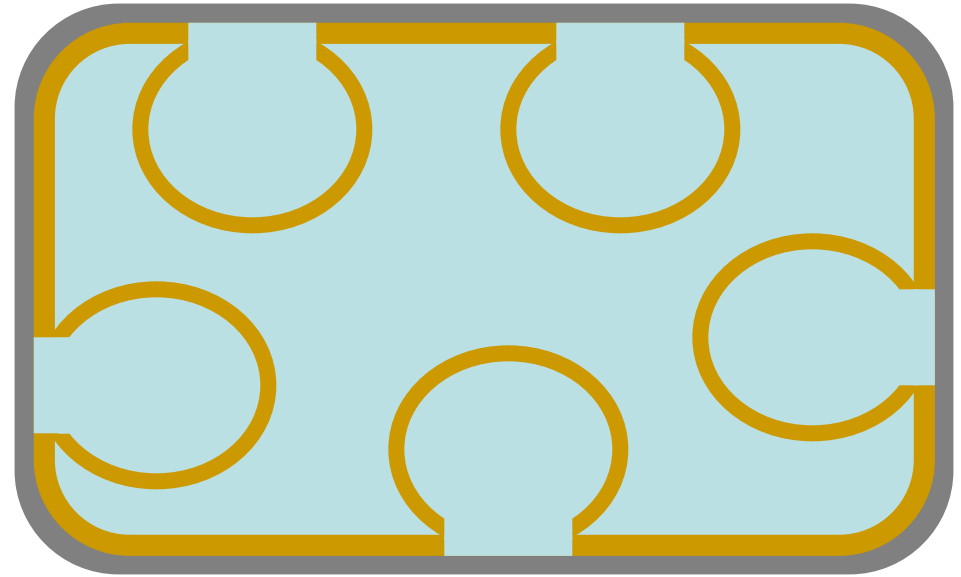

**CELL**

## COMPONENT PATHWAYS



# AEROBIC RESPIRATION

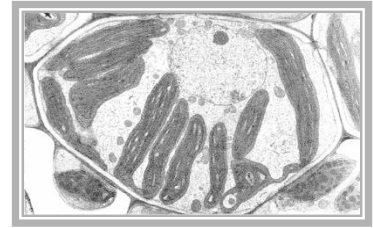

K

GLYCOLYSIS

CELL

## COMPONENT PATHWAYS



# AEROBIC RESPIRATION

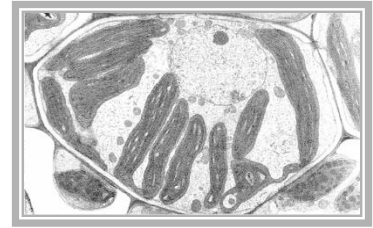

E

GLYCOLYSIS



KREBS CYCLE

CELL

## COMPONENT PATHWAYS



# AEROBIC RESPIRATION

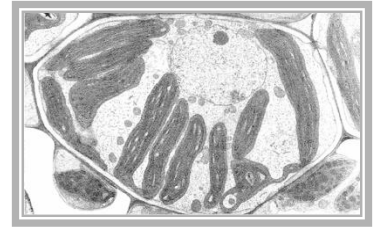

G

GLYCOLYSIS



KREBS CYCLE



ETC

CELL

## COMPONENT PATHWAYS



# GLYCOLYSIS

# SUMMARY

# AEROBIC RESPIRATION

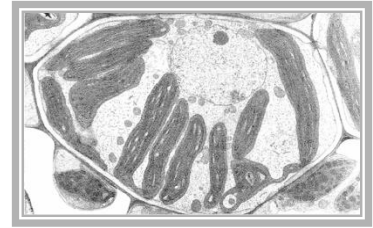
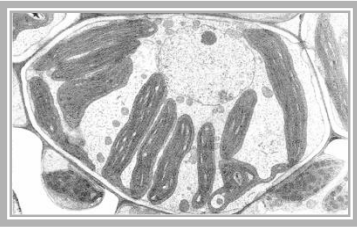

#

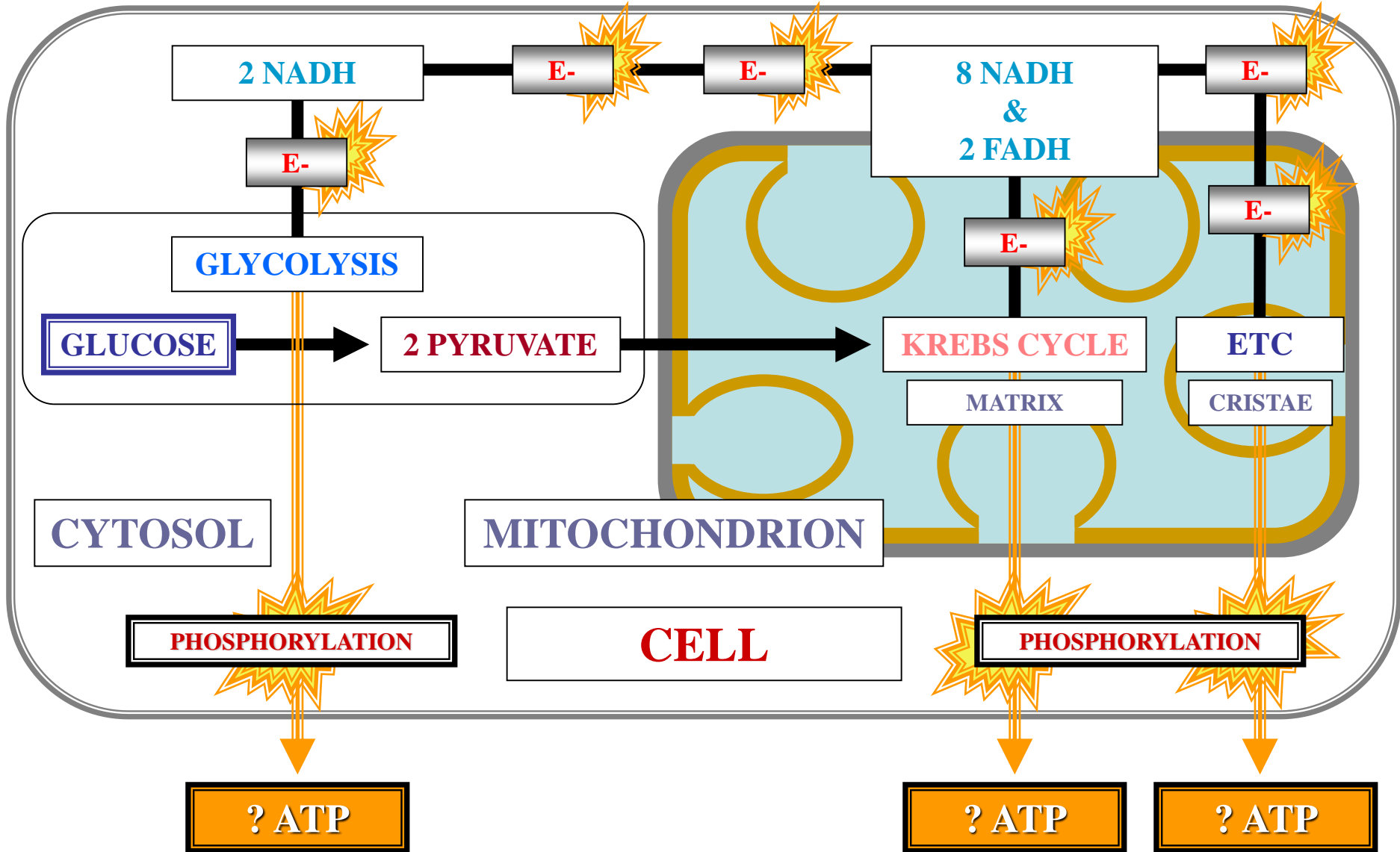



# AEROBIC RESPIRATION

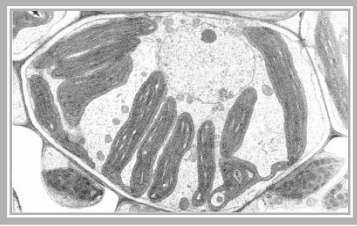

**P**  
**D**

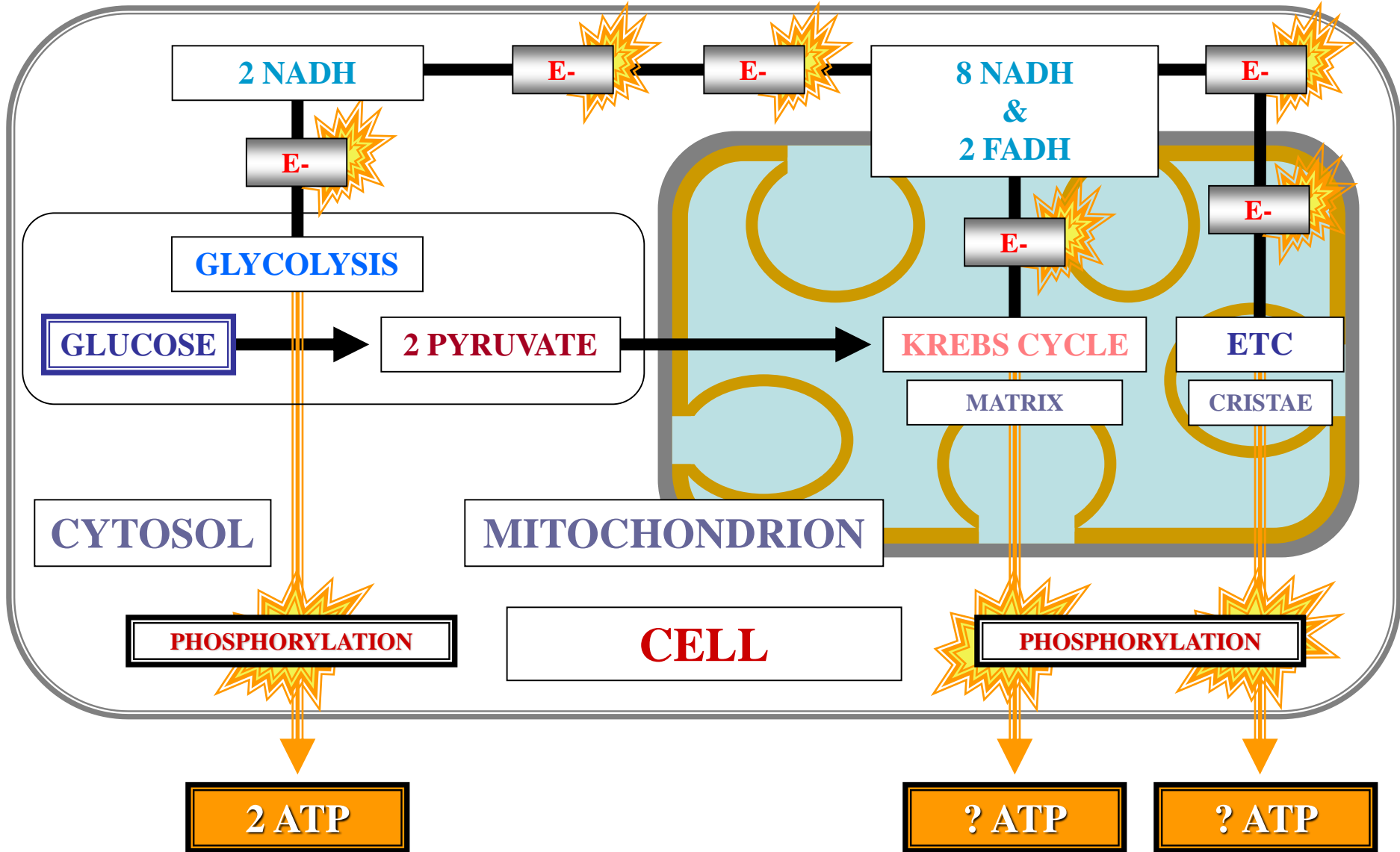

# GLYCOLYSIS

## SUBSTRATE PHOSPHORYLATION

**DIRECT ENZYME  
SUBSTRATE  
PHOSPHORYLATION**

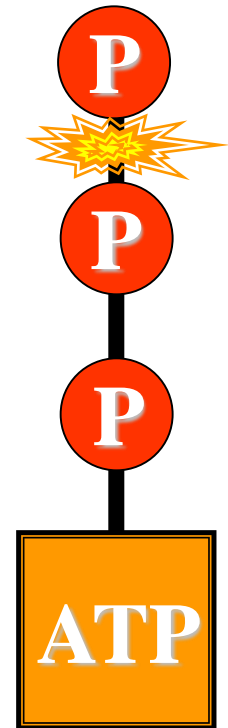

**!!!ETC: ABSENT!!!**

 = CHEM ENERGY



# KREBS CYCLE SUMMARY

# AEROBIC RESPIRATION

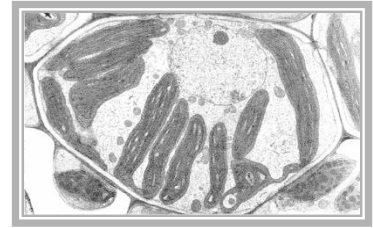
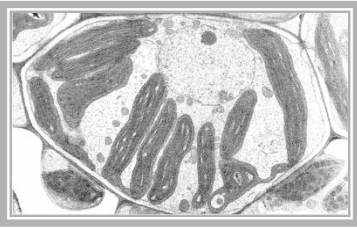

#

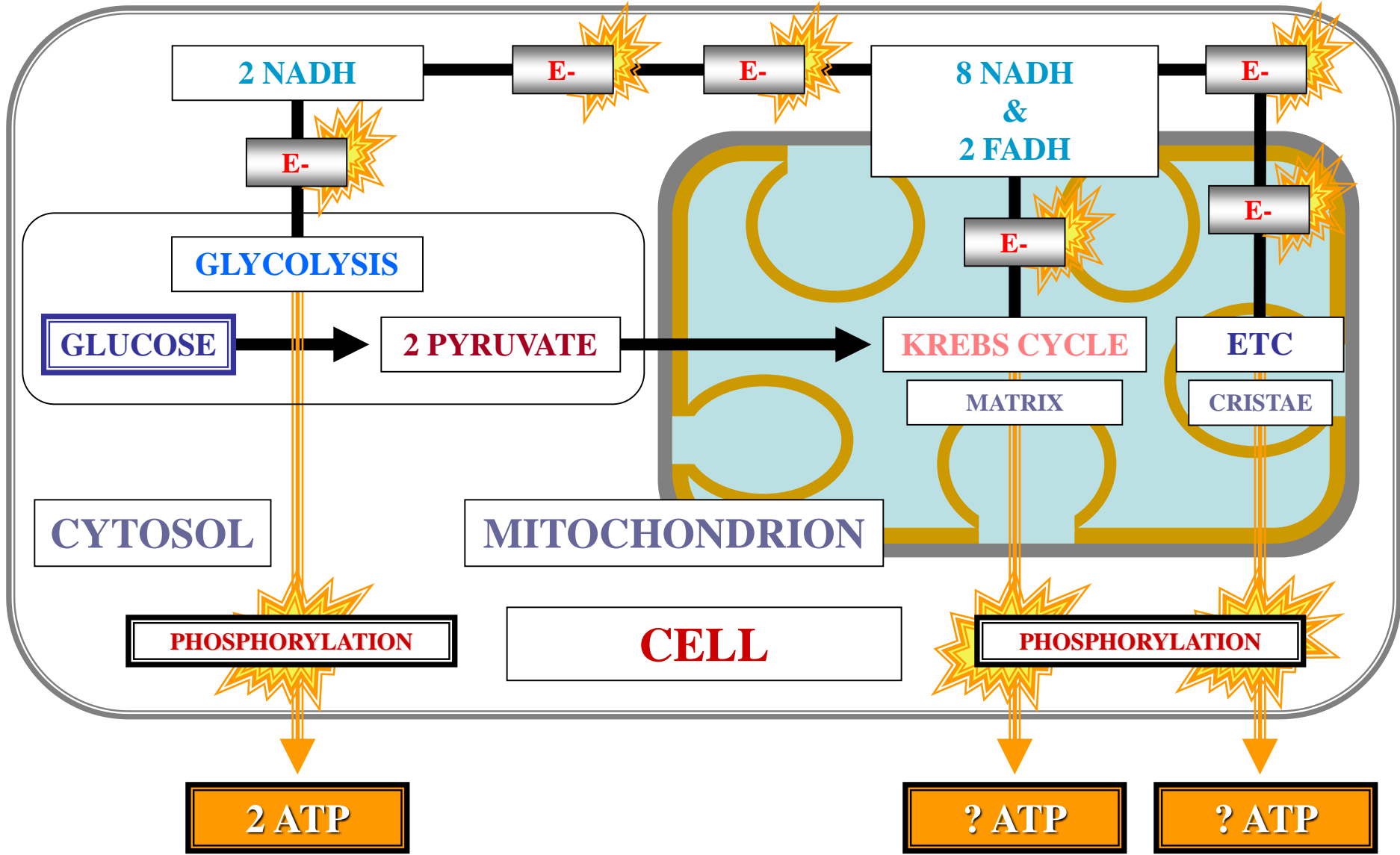

# AEROBIC RESPIRATION

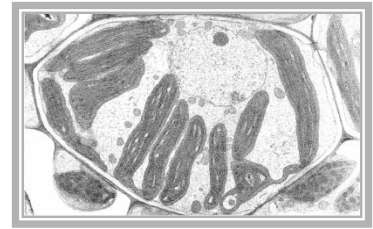
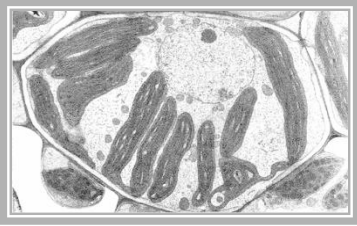

P

D

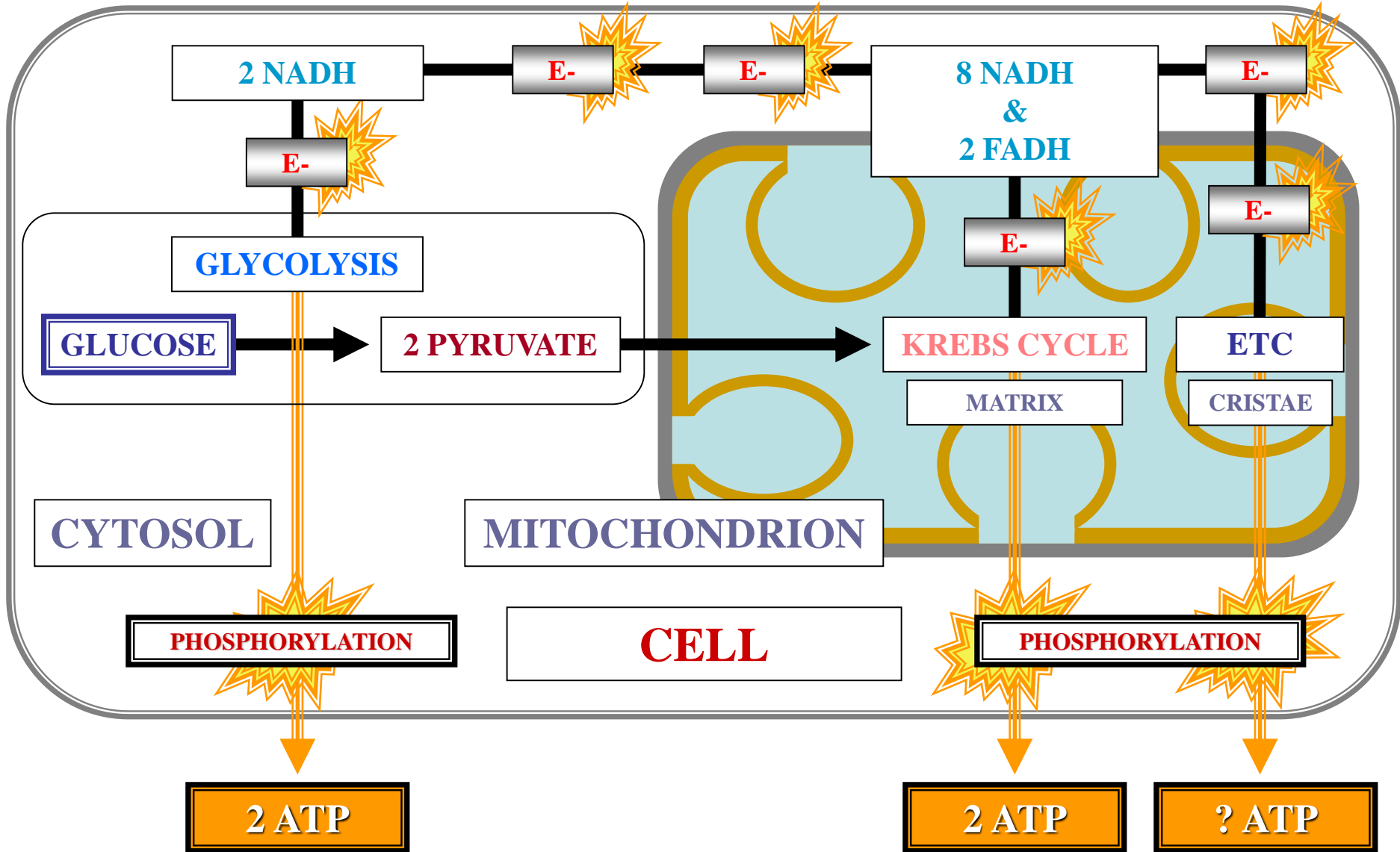

# KREBS CYCLE

## SUBSTRATE PHOSPHORYLATION

**DIRECT ENZYME  
SUBSTRATE  
PHOSPHORYLATION**

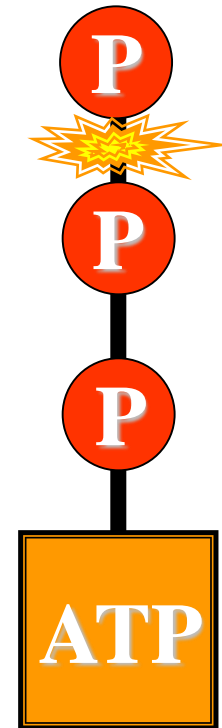

**!!!ETC: ABSENT!!!**

 = CHEM ENERGY



# ETC SUMMARY

# AEROBIC RESPIRATION

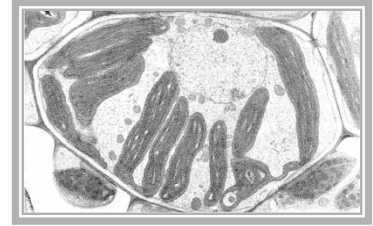

#

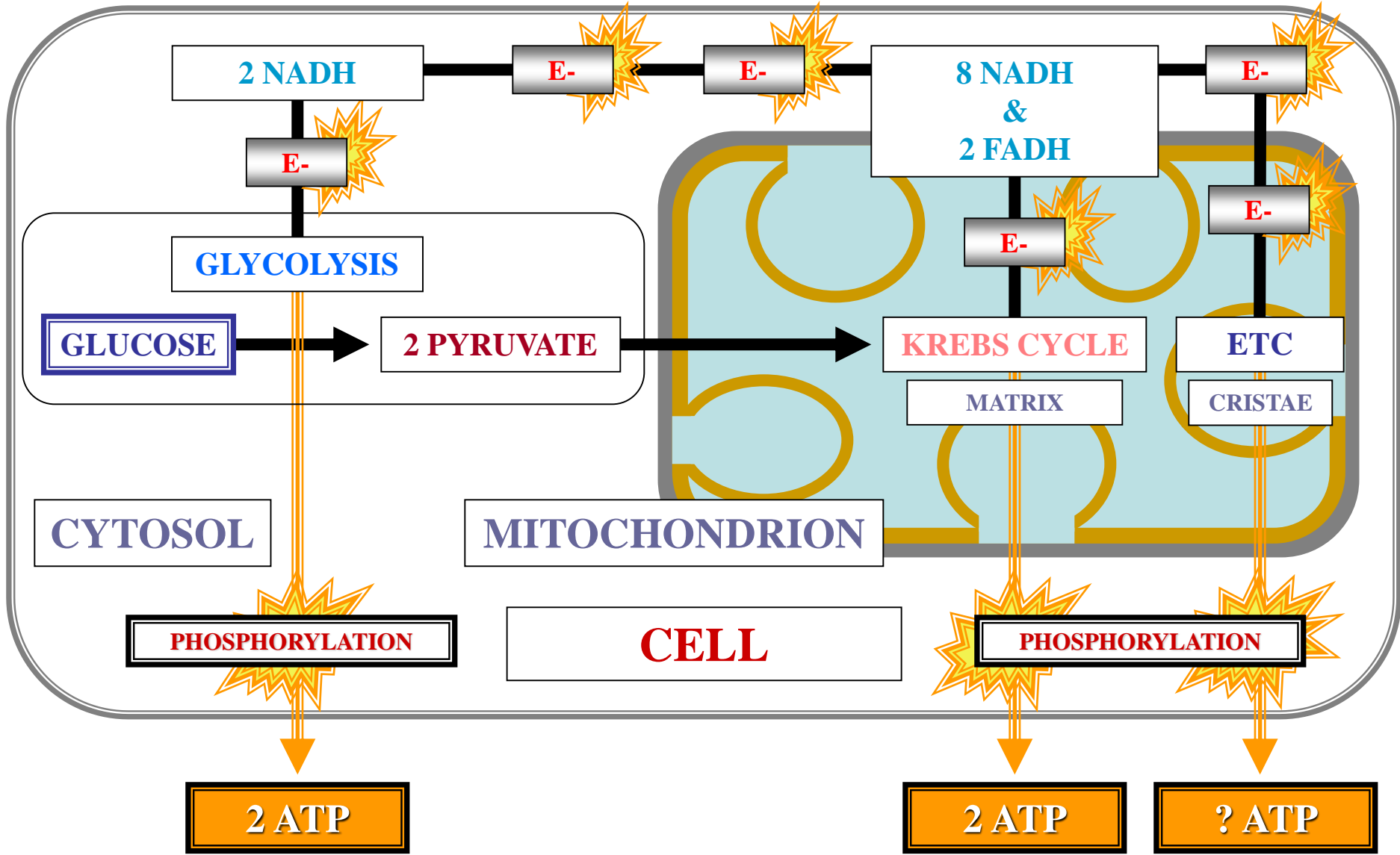



# AEROBIC RESPIRATION

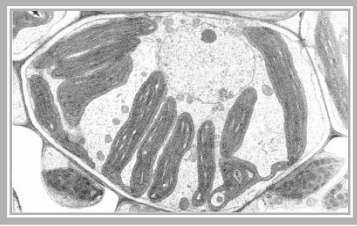

P

O

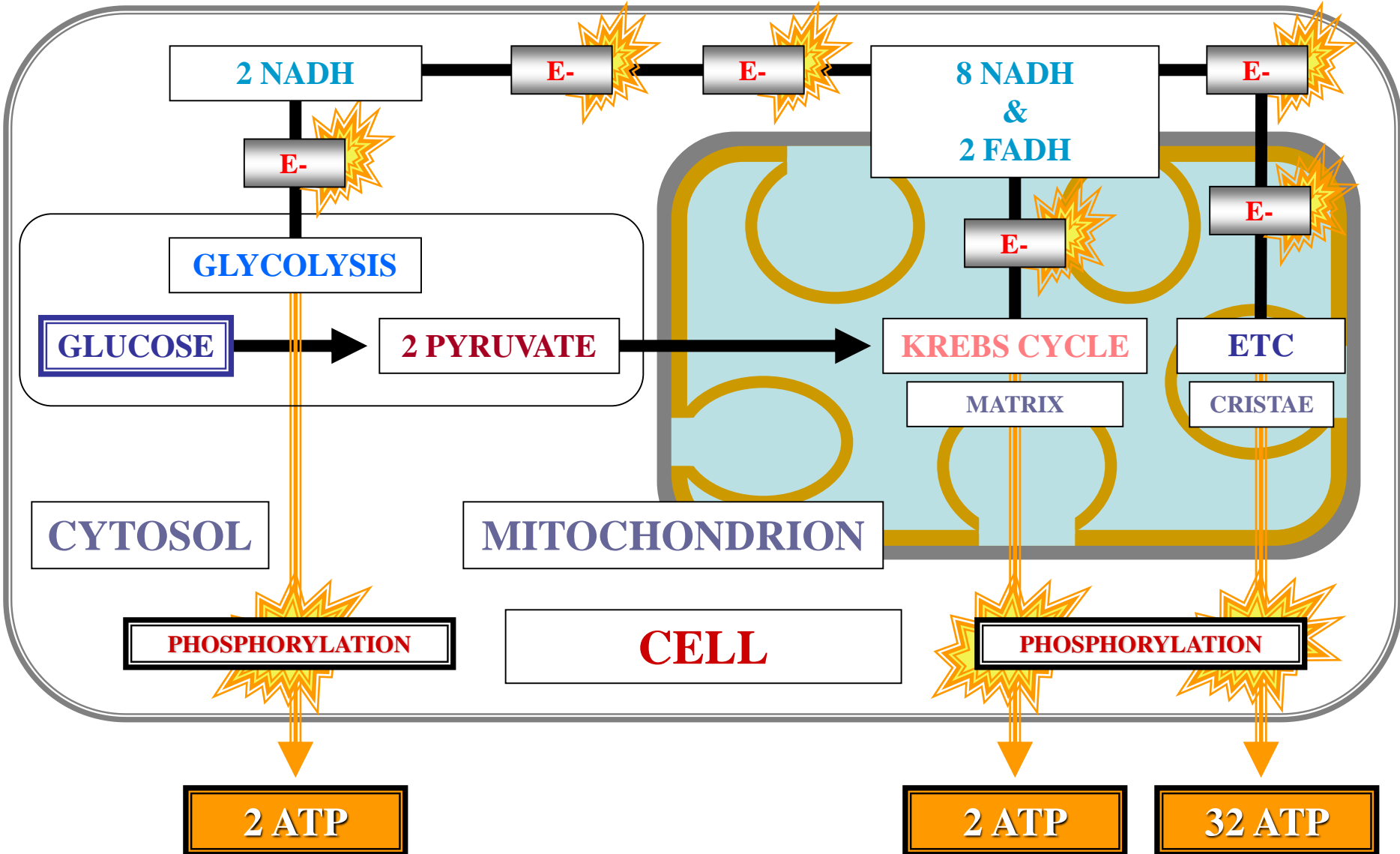

# OXIDATIVE CHEMIOSMOTIC PHOSPHORYLATION

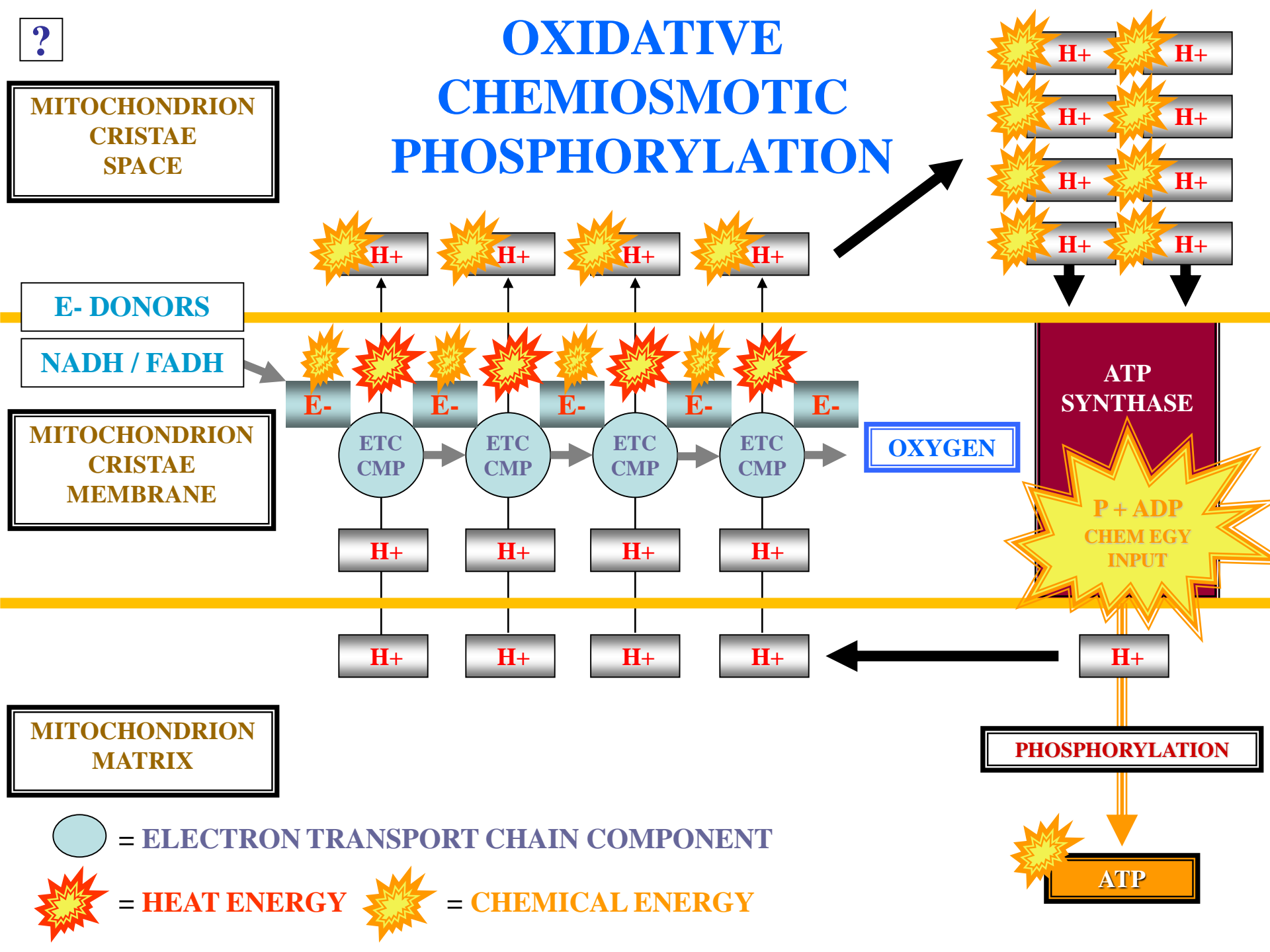

?

MITOCHONDRION  
CRISTAE  
SPACE

E- DONORS

NADH / FADH

MITOCHONDRION  
CRISTAE  
MEMBRANE

OXYGEN

ATP  
SYNTHASE

P + ADP  
CHEM EGY  
INPUT

MITOCHONDRION  
MATRIX

PHOSPHORYLATION

ATP

● = ELECTRON TRANSPORT CHAIN COMPONENT

★ = HEAT ENERGY    ★ = CHEMICAL ENERGY

**QUESTION**

**HOW MANY NET ATP**

**VIA**

**AEROBIC**

**RESPIRATION?**

**QUESTION**



# AEROBIC RESPIRATION

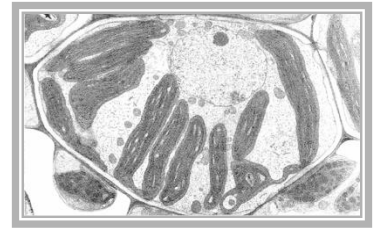
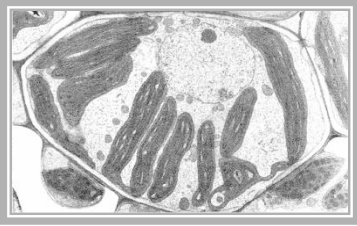

#

